



An Australian Government Initiative
Standard Business Reporting

SBR

Standard Business Reporting

SRO VIC Payroll Tax Annual Reconciliation Message Implementation Guide

Program name: *Standard Business Reporting*

Date: ~~20 October 2011~~ 26 July 2012

Production Release – suitable for use

 This document and its attachments are **Unclassified**



For further information or questions, contact the SBR Service Desk at SBRServiceDesk@sbr.gov.au or call 1300 488 231. International callers may use +61-2-6216 5577

VERSION CONTROL

Version	Release date	Description of changes
1.2	16/12/2009	Final Draft
2.0	28/01/2010	Production Release – Suitable for use
2.1	22/07/2010	<p>Updates as per PTARVIC.0001.02.00_Cover_Note_V1.0.</p> <p>Changes are as follows :</p> <ul style="list-style-type: none"> • Fixed incorrect TREF namings to align to the current published taxonomy • Fixed incorrect message code namings ; e.g. VIC.SRO.GEN.23 to VIC.SRO.PTX.23 • Fixed incorrect tuple sequence numbering in the message content table • Fixed incorrect enumerations • For conditional elements provided message codes for when element is not required. • Replaced message code SBR.GEN.GEN.1 with VIC.SRO.AUTH.19 • Replaced message code VIC.SRO.GEN.2 with VIC.SRO.PTX.32 • New message code VIC.SRO.PTX.67 for OMG overpayments • Specified multiple possible return codes for duplicate lodgements • Updated hypercube names to match published Taxonomy
3.0	20/10/2011	<ul style="list-style-type: none"> • Move common services out into the new Common MIG (e.g. authorisation of intermediaries, response messages, monetary amount, business applicability period) • Incorporate updates from latest SBR MIG template (V6.1) • Adopt RFC2119 standards • Payment Reference Tuple elements – order same • new validation for group estimates • new pre-fill response message for part payments • General text review and update for consistency/accuracy • Removed example instance from DTS references
<u>4.0</u>	<u>26/07/2012</u>	<ul style="list-style-type: none"> • <u>MIG V6.2 template changes (copyright, URLs, typos)</u> • <u>'PayrollTax.Deduction.LiabilityInclusion.Indicator' – removed from Reporting Party Calculate Request and Lodge Request</u>

Formatted Table

Formatted: Bulleted + Level: 1 +
Aligned at: 0.69 cm + Indent at: 1.33 cm

		<ul style="list-style-type: none"> • <u>'OrganisationDetails.EmploymentStateOrTerritory.Code' – removed 'All' as a valid option in Lodge Request for all employer types (NGE, DGE, OM, OSM)</u> • <u>TaxRate tuple : added to Calculate Response</u> • <u>New rules in 'Lodge Request' for Vic & Interstate cease dates, and interstate employment commencement date</u> • <u>1.3 References – updated links</u> • <u>Removal of Schematron rules</u> • <u>New taxonomy release</u>
--	--	---

Formatted: French (France)

ENDORSEMENT

APPROVAL

Helen Austin

Chief Solutions Architect
Solutions Integration
 Standard Business Reporting

Brendan Harrison

Manager Operations Strategy and Data Improvement
 State Revenue Office – Victoria
 Department of Treasury and Finance

Copyright

© Commonwealth of Australia 2014²

This work is copyright. Use of the Information and Material is subject to the terms and conditions in the "SBR Disclaimer and Conditions of Use-" which is available at <http://www.sbr.gov.au>. You must ensure that you comply with those terms and conditions. In particular, those terms and conditions include disclaimers and limitations on the liability of the Commonwealth and an indemnity from you to the Commonwealth and its personnel, the SBR Agencies and their personnel.

Formatted: Underline, Font color: Custom Color(RGB(5,5,61))

You must include this copyright notice in all copies of this Information and Material which you create. If you modify, adapt or prepare derivative works of the Information and Material, the notice must still be included but you must add your own copyright statement to your modification, adaptation or derivative work which makes clear the nature of your modification, adaptation or derivative work and you must include an acknowledgement that the adaptation, modification or derivative work is based on Commonwealth or Agency owned Information and Material. Copyright in SBR Agency specific aspects of the SBR Reporting Taxonomy is owned by the relevant SBR Agency.

Table of contents

1	Introduction	776
1.1	Purpose	776
1.2	Audience and Scope	776
1.3	References	776
1.4	Change Management	887
2	General Instructions	998
2.1	Authorisation of Intermediaries	998
2.2	Monetary Amount	998
2.3	Declarations	998
2.4	SBDH Variations	998
2.4.1	Business Documents	998
2.4.2	Attachments	998
2.4.3	Document Identifiers	998
2.4.4	Lodgment Date and Time Interpretation	10409
2.5	Response Messages	10409
2.6	Rule Expression	10409
2.6.1	Tuples and Context	10409
2.6.2	Format Rules	10409
2.7	XML Attributes	10409
3	Business Overview	114110
3.1	Business Applicability Period	131312
3.2	Report Version	131312
3.3	Retention Of Previously Lodged Data	131312
4	XBRL Context Specifications	141413
4.1	Context Specification – Reporting Party	141413
4.2	Context Specification – ReportingParty.EmployerGroupStatus	164615
4.2.1	GroupStatus context instances, labels and hypercubes	174716
4.2.2	Employer Types	191918
4.2.3	Start and End Dates	222221
4.2.4	Employs Interstate	222221
4.3	Context Specification – Government Agency	232322
5	SRO VIC Payroll tax Annual Reconciliation Interaction Model	242423
5.1	Prerequisites	242423
5.2	Service Summary	242423
5.2.1	Lodge Interaction	252524
5.2.2	Re-Lodge Interaction	262625
5.3	List Historic Returns Specifications	262625
5.4	List Outstanding Obligations Specifications	272726
5.5	Pre-Fill Annual Reconciliation Specifications	272726
5.5.1	Pre-fill Annual Reconciliation Request - Message	272726
5.5.1.1	Discoverable Taxonomy Set References	272726
5.5.1.1	Standard Business Document Header Content	282827
5.5.1.2	Standard Business Document Body Content	292928
5.5.2	Pre-fill Annual Reconciliation Response - Message	313130
5.5.2.1	Discoverable Taxonomy Set References	313130
5.5.2.2	Standard Business Document Header Content	313130
5.5.2.3	Standard Business Document Body Content	313130
5.6	Calculate Annual Reconciliation Specifications	373736
5.6.1	Calculate Annual Reconciliation Request - Message	383837
5.6.1.1	Discoverable Taxonomy Set References	383837
5.6.1.2	Standard Business Document Header Content	383837
5.6.1.3	Standard Business Document Body Content	393938
5.6.2	Calculate Annual Reconciliation Response - Message	505049
5.6.2.1	Discoverable Taxonomy Set References	505049

5.6.2.2	Standard Business Document Header Content.....	505049
5.6.2.3	Standard Business Document Body Content	505049
5.7	Lodge Annual Reconciliation Specifications	555554
5.7.1	Lodge Annual Reconciliation Request - Message	565655
5.7.1.1	Discoverable Taxonomy Set References.....	565655
5.7.1.2	Standard Business Document Header Content.....	575756
5.7.1.3	Standard Business Document Body Content	575756
5.7.2	Lodge Annual Reconciliation Response - Message	787875
5.7.2.1	Discoverable Taxonomy Set References.....	787875
5.7.2.2	Standard Business Document Header Content.....	787875
5.7.2.3	Standard Business Document Body Content	787875
Appendix A – The Message Content Table Explained		828279
1	Introduction	7
1.1	Purpose.....	7
1.2	Audience and Scope	7
1.3	References	7
1.4	Change Management	8
2	General Instructions	9
2.1	Authorisation of Intermediaries.....	9
2.2	Monetary Amount	9
2.3	Declarations	9
2.4	Standard Business Document Message (SBDM) Variations	9
2.4.1	Business Documents	9
2.4.2	Attachments	10
2.4.3	Document Identifiers.....	10
2.4.4	Lodgment Date and Time Interpretation	10
2.5	Response Messages	10
2.6	Rule Expression.....	11
2.6.1	Tuples and Context	11
2.6.2	Format Rules	11
2.7	XML Attributes	11
3	Business Overview	12
3.1	Business Applicability Period	14
3.2	Report Version	14
3.3	Retaining Of Previously Lodged Data	14
4	XBRL Context Specifications	15
4.1	Context Specification – Reporting Party	15
4.2	Context Specification – ReportingPartyEmployerGroupStatus	17
4.2.1	GroupStatus context instances, labels and hypercubes	18
4.2.2	Employer Types	20
4.2.3	Start and End Dates	22
4.2.4	Employs Interstate	23
4.3	Context Specification – Government Agency	24
5	SRO VIC Payroll tax Annual Reconciliation Interaction Model	25
5.1	Prerequisites.....	25
5.2	Service Summary	26
5.2.1	Lodge Interaction	26
5.2.2	Re-Lodge Interaction.....	27
5.3	List Historic Returns Specifications	28
5.4	List Outstanding Obligations Specifications	28
5.5	Pre-Fill Annual Reconciliation Specifications	28
5.5.1	Pre-fill Annual Reconciliation Request – Message	29
5.5.1.1	Discoverable Taxonomy Set References	29
5.5.1.1	Standard Business Document Header Content	29
5.5.1.2	Standard Business Document Body Content	30
5.5.2	Pre-fill Annual Reconciliation Response – Message	32

5.5.2.1	Discoverable Taxonomy Set References	32
5.5.2.2	Standard Business Document Header Content	32
5.5.2.3	Standard Business Document Body Content	32
5.6	Calculate Annual Reconciliation Specifications	38
5.6.1	Calculate Annual Reconciliation Request – Message	39
5.6.1.1	Discoverable Taxonomy Set References	39
5.6.1.2	Standard Business Document Header Content	39
5.6.1.3	Standard Business Document Body Content	40
5.6.2	Calculate Annual Reconciliation Response – Message	51
5.6.2.1	Discoverable Taxonomy Set References	51
5.6.2.2	Standard Business Document Header Content	51
5.6.2.3	Standard Business Document Body Content	51
5.7	Lodge Annual Reconciliation Specifications	56
5.7.1	Lodge Annual Reconciliation Request - Message	57
5.7.1.1	Discoverable Taxonomy Set References	57
5.7.1.2	Standard Business Document Header Content	58
5.7.1.3	Standard Business Document Body Content	58
5.7.2	Lodge Annual Reconciliation Response – Message	78
5.7.2.1	Discoverable Taxonomy Set References	78
5.7.2.2	Standard Business Document Header Content	78
5.7.2.3	Standard Business Document Body Content	78
Appendix A	The Message Content Table Explained	82

List of Figures

Figure 1 – PTX Business Context Overview for SRO VIC	124214
Figure 2 – Lodge Payroll Tax Annual Reconciliation Workflow for SRO VIC	252524
Figure 3 – Re-lodge Payroll Tax Annual Reconciliation Workflow for SRO VIC	262625
Figure 1 – PTX Business Context Overview for SRO VIC	11
Figure 2 – Lodge Payroll Tax Annual Reconciliation Workflow for SRO VIC	24
Figure 3 – Re-lodge Payroll Tax Annual Reconciliation Workflow for SRO VIC	25

Terminology

For definition of the terminology and acronyms used within this document please refer to the glossary on the SBR website – Click here

<https://www.sbr.gov.au/content/public/help/glossary> <http://www.sbr.gov.au/software-developers/developer-tools/glossary> to go to the glossary.

The key words “MUST”, “MUST NOT”, “REQUIRED”, “SHALL”, “SHALL NOT”, “SHOULD”, “SHOULD NOT”, “RECOMMENDED”, “MAY”, and “OPTIONAL” in this document are to be interpreted as described in RFC 2119 <http://www.ietf.org/rfc/rfc2119.txt>. The use of the word “Mandatory” is to be read as “MUST”.

1 INTRODUCTION

1.1 PURPOSE

The purpose of this document is to support software developers in the implementation of the SBR payroll tax reporting service for the ~~state of Victoria~~ [State Revenue Office – Victoria \(SRO VIC\)](#).

This document must be read in conjunction with the *SBR SRO VIC Common Message Information Guide* and should be read in conjunction with the *State and Territory Revenue Office Payroll Tax Common Message Implementation Guide OverviewMIG*.

1.2 AUDIENCE AND SCOPE

This document contains the necessary information required to support ~~State Revenue Office of Victoria (SRO VIC)~~ [the SRO VIC](#) implementation of the SBR channel for Payroll Tax Annual Reconciliations. Its primary audience is software developers and it comprises:

- The SRO VIC specific implementations of the Payroll Tax reference model.
- Detailed descriptions of each interaction.
- Links to the XBRL, WSDL, and Security implementations.

1.3 REFERENCES

Ref	Document Link	Document description
1)	State and Territory Revenue Office Payroll Tax Common Message Implementation Guide OverviewMIG document can be downloaded at http://www.sbr.gov.au/software-developers/developer-tools/vic-osr/sro-vic-ptmrhttps://www.sbr.gov.au/content/myhome/softwaredevelopers/downloads/commoncomponents (requires login)	This is the entry document to the individual SRO MIGs. This document provides a holistic view of the SRO payroll tax solutions and highlights where opportunities for consistent solutions have been adopted.
2)	The SBR Web Service Implementation Guide document can be downloaded at http://www.sbr.gov.au/software-developers/developer-tools/web-serviceshttps://www.sbr.gov.au/content/myhome/softwaredevelopers/downloads/commoncomponents (requires login)	Technical interface data that is common to all business processes and messages that use the SBR channel: <ul style="list-style-type: none"> • Web service protocol specifications • Standard message header structure • Standard error codes • Authentication protocol and trust broker
3)	The SBR Taxonomy Architecture document can be downloaded at http://www.sbr.gov.au/software-developers/developer-tools/re-	Reference document that describes the structure of the SBR taxonomy, its naming conventions, release management and change control, and how each business interaction fits

Formatted: Font: Bold

Formatted: Font: Bold

Formatted: Font: Bold

	usable-componentshttps://www.sbr.gov.au/content/myhome/softwaredevelopers/downloads/commoncomponents (requires login)	within the architecture.
4)	The Software Developer Kit documentation can be accessed at http://www.sbr.gov.au/software-developers/enabling-sbr-in-my-application/productivity-tools https://www.sbr.gov.au/content/myhome/softwaredevelopers/sdkguide (requires login)	Reference information for software developers using the SBR software developer kit
5)	SRO VIC Payroll Tax Monthly Return Message Implementation Guide can be accessed downloaded at: http://www.sbr.gov.au/software-developers/developer-tools/vic-osr/sro-vic-ptmr https://www.sbr.gov.au/content/myhome/softwaredevelopers/downloads/vicsro-ptmr	This document contains the necessary information required to support State Revenue Office of Victoria (SRO VIC) implementation of the SBR channel for Payroll Tax Monthly Returns.
6)	SRO VIC Payroll Tax Common Message Implementation Guide can be accessed downloaded at: http://www.sbr.gov.au/software-developers/developer-tools/vic-osr/sro-vic-ptmr , https://www.sbr.gov.au/content/myhome/softwaredevelopers/downloads/vicsro-common	This document contains the necessary information required to support the State Revenue Office of Victoria (SRO VIC) implementation of the SBR channel for Payroll Tax common services.

Formatted: Font: Not Bold

Formatted: Font: Not Bold

Formatted: Font: Bold

Formatted: Font: Bold

Formatted: Font: Bold

1.4 CHANGE MANAGEMENT

If a material change is required to ~~the SRO VIC Payroll Tax Annual Reconciliation~~[this](#) Message Implementation Guide (MIG) the document shall be re-released. The Taxonomy Approval Committee must approve any change.

2 GENERAL INSTRUCTIONS

This section provides instructions that are relevant across all collaborations and messages specified within this MIG.

2.1 AUTHORISATION OF INTERMEDIARIES

Refer to Section 2.1 – Authorisation of Intermediaries - in the SRO VIC Payroll Tax Common MIG for details on the authorisation of intermediaries with Payroll Tax Returns.

2.2 MONETARY AMOUNT

Refer to Section 2.2 – Monetary Amount – in the SRO VIC Payroll Tax Common MIG for details on monetary amount.

2.3 DECLARATIONS

A user provides a declaration when registering for payroll tax with SRO VIC.

However, there is no explicit declaration required within the messages sent by SBR.

2.4 ~~STANDARD BUSINESS DOCUMENT MESSAGE (SBDM)~~SBDH VARIATIONS

The [Web Services Information Guide \(WIG\)](#) describes the [SBDM-Standard Business Document Header \(SBDH\)](#) content in detail. Described in this section are only variations from what is defined in the WIG. The [Standard Business Document Message \(SBDM\)](#) contains the [Standard Business Document Header \(SBDH\)](#) and Standard Business Document Body (SBDB).

2.4.1 Business Documents

Only one business document in the Standard Business Document Body (SBDB) per message will be accepted for SRO VIC request messages. Any request message containing more than one business document will be rejected.

All SRO VIC response messages defined in this document will contain at most one business document.

2.4.2 Attachments

No attachments will be accepted or provided for SRO VIC interactions. Any messages containing attachments will be rejected.

2.4.3 Document Identifiers

The `sbdm:BusinessDocument.BusinessGeneratedIdentifier.Text` will be used in the Lodge Annual Reconciliation Request message to uniquely identify the lodgement request. This identifier is generated by the software package. Only a single identifier value for a given form type, return period and reporting party ABN, will be accepted.

Successive lodgements with duplicate values for sbdm:BusinessDocument.BusinessGeneratedIdentifier.Text will be rejected as duplicate lodgement attempts.

The sbdm:Lodgement.Receipt.Identifier will be used in the Lodge Annual Reconciliation Response message to uniquely identify the Lodgement. This identifier is generated by SRO VIC. It will be populated for successful lodgements only.

2.4.4 Lodgment Date and Time Interpretation

The SBDH contains a lodgement receipt date and time. This is contained in the element Lodgement.Receipt.Datetime, which it is in xs:dateTime format and will be provided in UTC time (not local). SRO VIC will populate this element for the Lodge Annual Reconciliation Response message only, for both successful lodgements and duplicate lodgements.

2.5 RESPONSE MESSAGES

Refer to Section 2.5 – Response Messages – in the SRO VIC Payroll Tax Common MIG for details on response messages.

2.6 RULE EXPRESSION

2.6.1 Tuples and Context

All facts reported in a tuple must use the same context.

2.6.2 Format Rules

There are format rules that will be applied to facts provided in request documents. Given that they are heavily reused and very simple, they have been included here rather than provided in the message tables below for each fact.

XBRL data type	Rules	Rule Imp.	SBR Msg Code
<i>Wage Fields</i>	<ol style="list-style-type: none"> 1. Must be greater than or equal to zero 2. Cents should not be provided 3. Must not exceed the maximum value (999,999,999,999) 	<ol style="list-style-type: none"> 1. Schematron-ID=VICMIG100MIG 2. Schematron-ID=VICMIG100MIG 3. Schematron-ID=VICMIG100MIG 	<ol style="list-style-type: none"> 1. VIC.SRO.GEN.6 2. VIC.SRO.GEN.7 3. VIC.SRO.GEN.8
<i>Payment Fields</i>	<ol style="list-style-type: none"> 1. Must be greater than or equal to zero 2. Precision should be no greater than 2 decimal places 3. Must not exceed the maximum value (999,999,999,999) 	<ol style="list-style-type: none"> 1. Schematron-ID=VICMIG104MIG 2. Schematron-ID=VICMIG104MIG 3. Schematron-ID=VICMIG104MIG 	<ol style="list-style-type: none"> 1. VIC.SRO.GEN.6 2. VIC.SRO.GEN.15 3. VIC.SRO.GEN.8

2.7 XML ATTRIBUTES

XML attributes will not be used in any of the Annual Reconciliation messages.

3 BUSINESS OVERVIEW

The Figure 1 – The SRO VIC Business Context for Payroll Tax Annual Reconciliations diagram below illustrates all possible interactions between the client and the VIC State Revenue Office (SRO) for an Annual Reconciliation.

- The top half shows interactions currently available to the Customer via the SRO VIC Portal (www.sro.vic.gov.au). In addition, a customer is also able to 'List' and 'Lodge' Payroll Tax Monthly Returns and Annual Reconciliations via the SRO VIC Portal
- The interactions which will be available via the SBR platform are shown in the second half of the diagram.
- These interactions cover the following business functions:
 1. Lodge Annual Reconciliation
 2. Re-Lodge Annual Reconciliation

Note:

This MIG only caters for Annual Reconciliations. However, the following will also be supported via the SBR platform:

- Lodge Periodic Return and Re-Lodge Periodic Return – instructions are provided in the SRO VIC Payroll Tax Monthly Return MIG
- List Historic and List Outstanding – instructions are provided in the SRO VIC Payroll Tax Common MIG

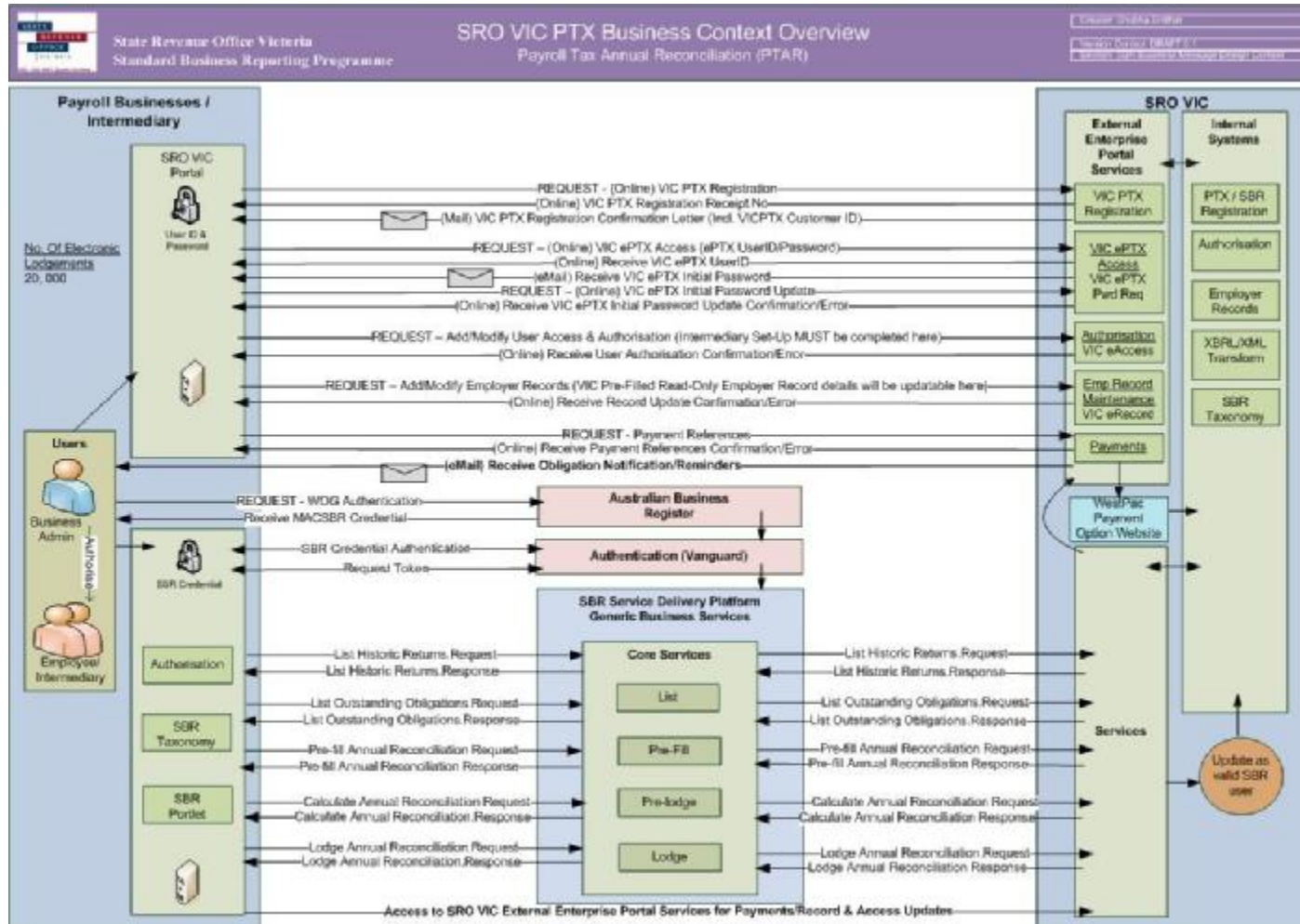

Figure 1 – PTX Business Context Overview for SRO VIC

3.1 BUSINESS APPLICABILITY PERIOD

Refer to Section 3.1 – Business Applicability Period - in the SRO VIC Payroll Tax Common MIG for details on the Business Applicability Period for Payroll Tax Returns.

3.2 REPORT VERSION

The current report version in SBR Reporting Taxonomy is ptarvic.0001.02.01~~9~~.

3.3 ~~RETAINING-RETENTION~~ OF PREVIOUSLY LODGED DATA

SRO VIC business process enables customers to:

- re-lodge a Payroll Tax Annual Reconciliation (PTAR) and
- view Payroll Tax Monthly Return (PTMR) lodgements when completing the PTAR

Therefore, it is expected/required that the following details be retained within the software package for redisplay:

- Annual Reconciliation lodgements in editable format in the event that the customer wishes to re-lodge a PTAR, and,
- Monthly Return lodgements in read-only format to assist in declaration of reconciliation period wages in the PTAR

4 XBRL CONTEXT SPECIFICATIONS

The following sections define the context specifications that will be used within this MIG. The context types are allocated to the individual data elements within the message specifications below.

4.1 CONTEXT SPECIFICATION – REPORTING PARTY

This context type defines the reporting party (i.e. the primary entity to which the report directly relates to) and their jurisdiction, in this case VIC.

XBRL Instance Context Data Concept	Requirement	Instructions/Rules	Rule Imp	SBR Msg code
Context Identifier	Mandatory	This is a unique identifier used to link the data element to a defined XBRL context. SBR is recommending a four character id starting with "C" and a three digit sequential number for each context e.g. C001 1. Must be a valid value	1. XBRL	1. NA
Entity Identifier	Mandatory	This field must be set to the ABN of the Reporting Party. 1. Must be a valid ABN 2. ABN must be registered with receiving agency	1. MIG 2. MIG	1. VIC.SRO.AUTH.19 2. SBR.GEN.GEN.13
Entity Identifier Scheme	Mandatory	1. This field must be set to " http://www.abr.gov.au/abn "	1. MIG	1. SBR.GEN.GEN.14
Entity Segment	Mandatory	1. Explicit member dimension ReportPartyType set to " h04.02.02:ReportingPartyRprtPyType.02.03:ReportingParty "	1. XBRL	1. NA
	Mandatory	1. Explicit member dimension AustralianStatesTerritoriesAndOffShoreAreas set to " h04.02.04:VICAuStsTerrOS.02.03:VIC "	1. XBRL	1. NA
Period Type	Mandatory	The period type must be set to the following start date and end date:		
Period Date - Start	Mandatory	1. Instructions & rules for both the Start and End Date will be provided at the	1. NA	1. NA

XBRL Instance Context Data Concept	Requirement	Instructions/Rules	Rule Imp	SBR Msg code
Date		message level.		
Period Date - End Date	Mandatory			

4.2 CONTEXT SPECIFICATION – REPORTINGPARTY.EMPLOYERGROUPSTATUS

This context is required to identify the reporting party, their jurisdiction and the group member structure they are reporting under.

XBRL Instance Context Data Concept	Requirement	Instructions/Rules	Rule Imp	SBR Msg code
Context Identifier	Mandatory	This is a unique identifier used to link the data element to a defined XBRL context. SBR is recommending a four character id starting with "C" and a three digit sequential number for each context e.g. C001 1. Must be a valid value	1. XBRL	1. NA
Entity Identifier	Mandatory	This field must be set to the ABN of the Reporting Party. 1. Must be a valid ABN 2. ABN must be registered with receiving agency	1. MIG 2. MIG	1. VIC.SRO.AUTH.19 2. SBR.GEN.GEN.13
Entity Identifier Scheme	Mandatory	1. This field must be set to " http://www.abr.gov.au/abn "	1. MIG	1. SBR.GEN.GEN.14
Entity Segment	Mandatory	1.Explicit member dimension ReportPartyType set to " h04.02.02:ReportingPartyRprtPyType.02.03:ReportingParty "	1. XBRL	1. NA
	Mandatory	1. Explicit member dimension AustralianStatesTerritoriesAndOffShoreAreas set to " h01.02.01:VICAuStsTerrOS.02.03:VIC "	1. XBRL	1. NA
	Mandatory	1.Explicit member dimension = EmployerGroupStatus set to one of the following values: " h02.02.03:NGEEmpGrpSts.02.04:NGE ", " h02.02.03:DGENSEmpGrpSts.02.04:DGENSEG ", " h02.02.03:DGEEmpGrpSts.02.04:DGE ", " h02.02.03:OMEmpGrpSts.02.04:OMG ", " h02.02.03:DGESGEmpGrpSts.02.04:DGESG ", " EmpGrpSts.02.04:h02.02.03:OSM ", or " h02.02.03:OMEmpGrpSts.02.04:OM ".	1. XBRL	1. NA

XBRL Instance Context Data Concept	Requirement	Instructions/Rules	Rule Imp	SBR Msg code
Period Type	Mandatory	The period type must be set to the following start date and end date:		
Period Date - Start Date	Mandatory	1. Instructions & rules for both the Start and End Date will be provided at the message level. And in section 4.2.1 below.	1. NA	1. NA
Period Date - End Date	Mandatory			

4.2.1 GroupStatus context instances, labels and hypercubes

The table below lists specific instances of the context specification above that will be used only within the Annual Return messages.

Context instance MIG Label	ABN	Dimensions with constrained values			Instructions/Rules	Rule Imp	SBR Msg code
		Report Party Type	Australian States Territories and Off Shore Areas	Group Status			
Non Group Employer (NGE)	Reporting Party ABN	ReportingParty	VIC	NGE	The reporting party is the NGE 1.Start Date must always be the same as the period defined in the reporting party context 2. End Date must always be the same as the period defined in the reporting party context	1. MIG 2. MIG	1. SBR.GEN.GEN.18 2. SBR.GEN.GEN.20
Designated Group Employer of a Scheduled Group (DGESG)	Reporting Party ABN	ReportingParty	VIC	DGESG	The reporting party is the DGESG 1.Start Date must always be the same as the period defined in the reporting party context 2. End Date must always be the same as the period defined in the reporting party context	1. MIG 2. MIG	1. SBR.GEN.GEN.18 2. SBR.GEN.GEN.20
Designated Group Employer of Non Scheduled Group (DGENSG)	Reporting Party ABN	ReportingParty	VIC	DGENSG	The reporting party is the DGENSG 1.Start Date must always be the same as the period defined in the reporting party context 2. End Date must always be the same as the period defined in the reporting party context	1. MIG 2. MIG	1. SBR.GEN.GEN.18 2. SBR.GEN.GEN.20

Context instance MIG Label	ABN	Dimensions with constrained values			Instructions/Rules	Rule Imp	SBR Msg code
		Report Party Type	Australian States Territories and Off Shore Areas	Group Status			
Ordinary Member of a Non Scheduled or Scheduled Group (OM)	Reporting Party ABN	ReportingParty	VIC	OM	The reporting party is the OM 1.Start Date must always be the same as the period defined in the reporting party context 2. End Date must always be the same as the period defined in the reporting party context	1. MIG 2. MIG	1. SBR.GEN.GEN.18 2. SBR.GEN.GEN.20
Designated Group Employer (DGE)	Reporting Party ABN	ReportingParty	VIC	DGE	Here the DGE reports facts about themselves as an employer that are not included in the ReportingParty context Use the dates supplied in the pre-fill response for the DGE 1.Start Date must always be the same as the start date supplied in the pre-fill response for the DGE 2. End Date must always be the same as the end date supplied in the pre-fill response for the DGE	1. MIG 2. MIG	1. SBR.GEN.GEN.18 2. SBR.GEN.GEN.20
Ordinary Scheduled Member of a Scheduled Group (OSM)	Group Member ABN	ReportingParty	VIC	OSM	Here the DGE reports facts about an OSM who is a member of the DGE's group. Use the dates supplied in the pre-fill response for the OSM 1.Start Date must always be the same as the start date supplied in the pre-fill response for the OSM 2. End Date must always be the same as the end date supplied in the pre-fill response for the OSM	1. MIG 2. MIG	1. SBR.GEN.GEN.18 2. SBR.GEN.GEN.20
Ordinary Member of a Scheduled or Non Scheduled Group (OMG)	Group Member ABN	ReportingParty	VIC	OMG	Here the DGE reports facts about an OM who is a member of the DGE's group. Use the dates supplied in the pre-fill response for the OMG 1.Start Date must always be the same as the start date supplied in the pre-fill response for the OMG 2. End Date must always be the same as the end date supplied in the pre-fill response for the OMG	1. MIG 2. MIG	1. SBR.GEN.GEN.18 2. SBR.GEN.GEN.20
Group Estimates (GRPEST)	Reporting Party ABN	ReportingParty	VIC	DGESG or DGENSG	This context is used to report group wage estimates for the next financial year in Victoria and interstate by a DGESG or DGENSG. 1.Start date must be the start date of the financial	1. MIG	1. SBR.GEN.GEN.18

Context instance MIG Label	ABN	Dimensions with constrained values			Instructions/Rules	Rule Imp	SBR Msg code
		Report Party Type	Australian States Territories and Off Shore Areas	Group Status			
					year following the reporting period. 2. End date must be the end date of the financial year following the reporting period	2. MIG	2. SBR.GEN.GEN.20
Reporting Party Estimates (RPEST)	Reporting Party ABN	ReportingParty	VIC	NGE, DGE, or OM	This context is used to report employer wages estimates for the next financial year in Victoria and interstate by a NGE, DGE or OM. 1.Start date must be the start date of the financial year following the reporting period. 2. End date must be the end date of the financial year following the reporting period	1. MIG 2. MIG	1. SBR.GEN.GEN.18 2. SBR.GEN.GEN.20
Ordinary Scheduled Member of a Scheduled Group Estimates (OSMEST)	Group Member ABN	ReportingParty	VIC	OSM	This context is used to report employer wages estimates for the next financial year in Victoria and interstate by an OSM. 1.Start date must be the start date of the financial year following the reporting period. 2. End date must be the end date of the financial year following the reporting period	1. MIG 2. MIG	1. SBR.GEN.GEN.18 2. SBR.GEN.GEN.20

4.2.2 Employer Types

The employer type (*also called employer group status*) is used to determine the reporting party's obligations. The information required for each employer type, and the calculation of their payroll tax liability, is different in each case. The employer types that are used by SRO VIC are:

1. Non Group Employer (NGE)
2. Designated Group Employer of a Scheduled Group (DGESG)
3. Designated Group Employer of a Non Scheduled Group (DGENSG)
4. Ordinary Member (OM)

Each of these employer types report to SRO VIC each year via an Annual Reconciliation, which, whilst recording other data, will determine the payroll tax payable by that employer or group of employers.

Reporting obligation

- **NGE** - is an employer who is not a member of a group and who is required to complete their own Annual Reconciliation
- **DGESG** - is an employer who has been nominated to report for a group of employers. The Scheduled group has members that are scheduled and (possibly) non scheduled:
 - **Scheduled members** - includes the DGE and Ordinary Scheduled Members (OSM). An OSM is not required to complete its own Annual Reconciliation, as their details are reported by the DGE of their group
 - **Non scheduled members** - are called Ordinary Members (OM). An OM is required to complete its own Annual Reconciliation, as well as their details also being reported on by the DGE of their group
- **DGENSG** - is an employer who has been nominated to report for a group of employers. A Non Scheduled group has only members that are non scheduled (i.e. includes the DGE and OM's). Each member is required to complete their own Annual Reconciliation, as well as their details also being reported on by the DGE of their group
- **OM** - is an employer who is a member of a group and who is required to complete their own Annual Reconciliation

In addition, the following Group Status types are also used:

1. **OMG** – this is where the employer type is really an OM, but is specifically used for where the DGE is reporting the OM's details in the aggregate figures collected in the total group data.
2. **DGE** – this is where the employer type is really a DGESG or DGENSG, but is specifically used for where the DGE is reporting their own details (*i.e. DGESG and DGENSG group status is used where the DGE reports facts about the group*).
3. **RPEST** – this is when the employer is completing their own Annual Reconciliation, where they are required to estimate their Gross Taxable Victorian and Gross Taxable Interstate wages for the financial year following the Annual Reconciliation period.
4. **GRPEST** - this is when the DGESG or DGENSG is completing the Group's Annual Reconciliation, where they are required to estimate the Group Gross Taxable Victorian and Group Gross Taxable Interstate wages for the financial year following the Annual Reconciliation period.
5. **OSMEST** – this is when the DGESG is reporting details for an OSM, where they are required to estimate the Gross Taxable Victorian Wages and Gross Taxable Interstate wages for the financial year following the Annual Reconciliation period for that OSM.

Contexts required for Annual Reconciliation scenarios

Reporting Party	Contexts required
Non Group Employer (NGE)	<ul style="list-style-type: none"> • NGE • RPEST
Designated Group Employer of a Scheduled Group (DGESG)	<ul style="list-style-type: none"> • DGESG • DGE • OSM for each OSM • OMG for each OM • GRPEST • RPEST • OSMEST for each OSM
Designated Group Employer of a Non Scheduled Group (DGENSG)	<ul style="list-style-type: none"> • DGENSG • DGE • OMG for each OM • GRPEST • RPEST
Ordinary Member (OM)	<ul style="list-style-type: none"> • OM • RPEST

'Interstate Only' Employers

One other type of employer exists, which is called an 'Interstate Only member'. These employers are members of a group who only employ interstate and not in Victoria. These members are not treated as individuals for reporting on an Annual Reconciliation, but are included in the aggregate figures collected in the total group data. These facts are collected in the DGESG and DGENSG contexts.

4.2.3 Start and End Dates

For a member of a group or a NGE the start and end dates of its reconciliation period commence with the earliest date of its Victorian employment period, interstate employment period or the 1st of July of the financial year. Its end date is the greatest of its Victorian employment period, interstate employment period or the 30th of June of the financial year.

Example 1:

If an employer employs from the 1st of January 2009 until the 1st of April 2009 in Victoria, and from the 15th of February 2009 until the 15th of April 2009 interstate, then its reconciliation period for the 2008/2009 financial year will be 1st of January 2009 until 15th of April 2009.

Example 2:

If an employer employs from 1st of January 2007 in Victoria and the 12th of February 2009 interstate and continues to do so, then for the 2008/2009 financial year its reconciliation period is the 1st of July 2008 until 30th of June 2009.

For a group its reconciliation period follows the same rules except applied across all members of the group (DGE, OMG and OSM). Thus each member will have potentially different reconciliation periods that reflect their employment periods. The group's reconciliation period is the greatest span of these dates, bounded by the start and end dates of the financial year.

The List Outstanding Obligations service returns a start and end date for each outstanding obligation for the reporting party. The start and end dates of the selected obligation should be used in the Pre-fill request as the dates on the ReportingParty context instance. The Pre-fill response will provide the GroupStatus context instances. These contexts' start and end dates are then used in the Calculate and Lodge requests.

4.2.4 Employs Interstate

A number of conditional rules depend upon whether the employer and/or group employs interstate. To determine this, look at the pre-fill response and if a PeriodDetails tuple is supplied with a Period.Type.Code of 'InterstateReconciliation' for the employer and/or group, then they are deemed to employ interstate.

4.3 CONTEXT SPECIFICATION – GOVERNMENT AGENCY

This context type defines the government agency (in this case SRO VIC). Note – this context is only used in response messages generated by SRO VIC.

XBRL Instance Context Data Concept	Requirement	Instructions/Rules	Rule Imp	SBR Msg code
Context Identifier	Mandatory	This is a unique identifier used to link the data element to a defined XBRL context. SBR is recommending a four character id starting with "C" and a three digit sequential number for each context e.g. C001 1. Must be a valid value	1. NA	1. NA
Entity Identifier	Mandatory	1. This field must be set to the ABN of SRO VIC.	1. NA	1. NA
Entity Identifier Scheme	Mandatory	1. This field must be set to " http://www.abr.gov.au/abn "	1. NA	1. NA
Entity Segment	Mandatory	1. Explicit member dimension ReportPartyType set to " h04.02.02:GovernmentAgencyRprtPyType.02.03:GovernmentAgency "	1. NA	1. NA
Period Type	Mandatory	The period type must be set to the following start date and end date		
Period Date - Start Date	Mandatory	1. Instructions & rules for both the Start and End Date will be provided at the message level.	1. NA	1. NA
Period Date - End Date	Mandatory			

5 SRO VIC PAYROLL TAX ANNUAL RECONCILIATION INTERACTION MODEL

Each financial year, all employers registered for Payroll Tax must lodge an Annual Reconciliation return. The Annual Reconciliation gives employers the opportunity to review the Payroll tax that they have paid for the financial year and make any necessary adjustments to correct overpayments or underpayments made during the year. The due date for lodgement of the Annual Reconciliation and payment of any amount outstanding is 21st July.

There is a legislative requirement for an employer to give written notification to the Commissioner of SRO VIC within 14 days of a change occurring in their circumstances (e.g. changes to legal name, grouping, employing dates). As the Annual Reconciliation via the SRO VIC portal is the sole enforced transaction for many employers, it is used to encourage them to provide a notification of record changes as well.

Employer record changes will not be allowed via the SBR channel. Record changes must continue to be advised via the SRO VIC portal prior to using the SBR channel for an Annual Reconciliation. That is before pre-fill, calculate or lodgement services are invoked via the SBR channel. If the record change is not subsequently reflected in the SBR channel, then the employer will be required to lodge their Annual Reconciliation using the SRO Vic portal.

5.1 PREREQUISITES

To successfully interact through the SBR channel to SRO VIC, a business must be:

- Registered with SRO VIC for Payroll Tax (and have provided a valid ABN)
- Have a valid AUSkey credential
- Linked their AUSkey to their Payroll Tax customer number

SRO VIC will recognise and accept lodgements from intermediaries subject to authorisation by the customer.

To use the SRO VIC Online Payment Facility (direct debit) the client must be registered for Online Payments with SRO VIC.

To lodge a PTMR, the business must be registered on a monthly cycle. Every employer registered for payroll tax in Victoria must pay tax every month, unless the Commissioner of State Revenue (the Commissioner) has given approval to pay tax annually. If the Commissioner approves the employer to pay tax annually, then they only need to lodge a PTAR.

5.2 SERVICE SUMMARY

The workflow defined below represents the abstract process model for the **Annual Payroll Tax Annual Reconciliation**. The following defines the sequence, optionality and repeatability of the service execution. Where a service is identified as '*Mandatory*' then the Software Developer has to implement this service as the service needs to be executed by the business in order to complete the transaction. Repeatability indicates if the service can be executed more than once – 'Yes' meaning that a service can be executed multiple times within the sequence.

5.2.1 Lodge Interaction

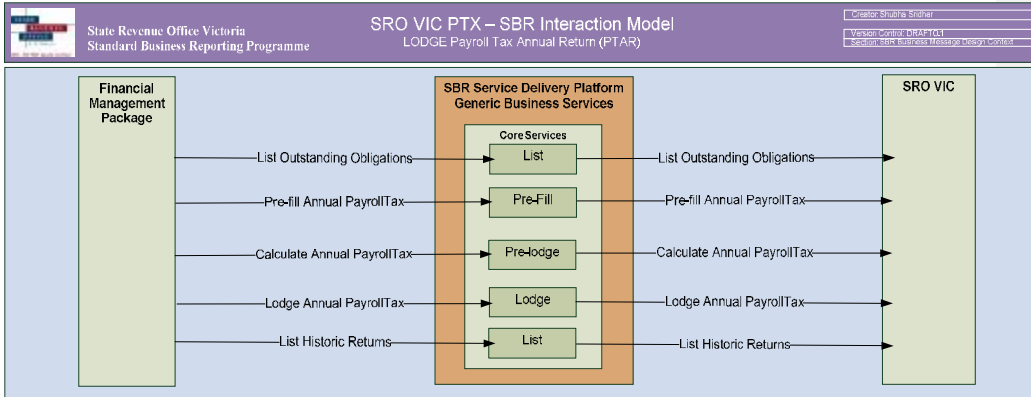

Figure 2 – Lodge Payroll Tax Annual Reconciliation Workflow for SRO VIC

	Service Name	Mandatory	Repeatability
1	List Outstanding Obligations This service will enable clients to query a summary listing of their outstanding obligations.	Yes	Yes
2	Pre-fill Annual Reconciliation PayrollTax This service enables clients to request employer and group details, and employment periods.	Yes	Yes
3	Calculate Annual Reconciliation PayrollTax This service enables clients to submit their Annual Reconciliation wages for VIC pre-fill information, validation and liability calculations, prior to formal lodgment of the Annual Reconciliation.	Yes	Yes
4	Lodge Annual Reconciliation PayrollTax This service enables clients to lodge their Payroll Tax Annual Reconciliation. If a client wishes to re-lodge a previously lodged Annual Reconciliation, they may do so via this service. Subsequent executions of this service are catered for in the “Re-lodge” interaction below.	Yes	Yes
5	List Historic Returns This service will enable clients to query a summary listing of their lodgments for the current and previous financial year.	No	Yes

5.2.2 Re-Lodge Interaction

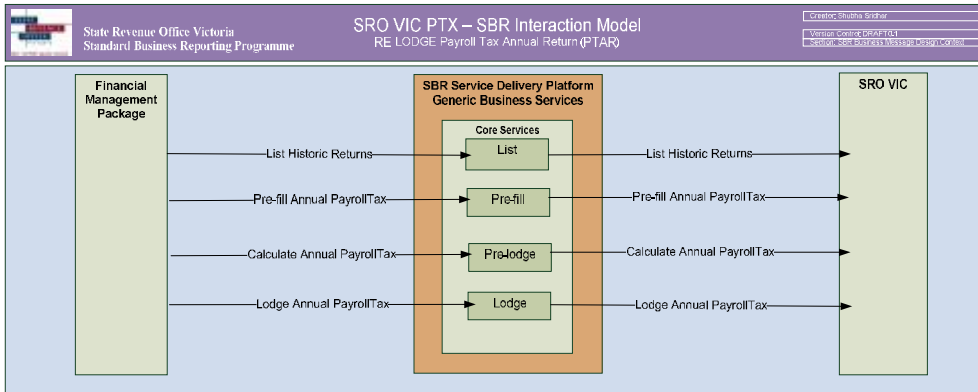

Figure 3 – Re-lodge Payroll Tax Annual Reconciliation Workflow for SRO VIC

	Service Name	Mandatory	Repeatability
1	List Historic Returns This service will enable clients to query a summary listing of their lodgments for the current and previous financial year.	No *	Yes
2	Pre-fill Annual Reconciliation PayrollTax This service enables clients to request employer and group details, and employment periods.	Yes	Yes
3	Calculate Annual Reconciliation PayrollTax This service enables clients to submit their Annual Reconciliation wages for VIC pre-fill information, validation and liability calculations, prior to formal lodgment of the Annual Reconciliation.	Yes	Yes
4	Lodge Annual Reconciliation PayrollTax This service enables clients to lodge their Payroll Tax Annual Reconciliation. If a client wishes to re-lodge a previously lodged Annual Reconciliation, they may do so via this service.	Yes	Yes

* Mandatory if the software package does not hold data from the prior lodgement.

5.3 LIST HISTORIC RETURNS SPECIFICATIONS

For the detail of this service please refer to the *SBR SRO VIC Payroll Tax Common Message Implementation Guide.doc*.

5.4 LIST OUTSTANDING OBLIGATIONS SPECIFICATIONS

For the detail of this service please refer to the *SBR SRO VIC Payroll Tax Common Message Implementation Guide.doc*.

5.5 PRE-FILL ANNUAL RECONCILIATION SPECIFICATIONS

Interaction Name	Pre-fill Annual Reconciliation
Description	The purpose of this interaction is as follows: § to enable businesses to request SRO VIC data to assist in completing their Annual Reconciliation § This service can be called multiple times.
Stakeholders	Business, State Revenue Offices and Intermediaries
Pre-conditions	§ Employer is registered for payroll tax in the State of Victoria § Employer has activated their SRO VIC customer record for SBR access via SRO VIC's portal application PTX Express § Employer record details held by SRO VIC are accurate and up to date § User has been authenticated via the VANguard Security Token Service (and the token is still valid). This token is valid across multiple transactions (until it expires). § User is authorised to lodge payroll tax on behalf of the employer, as: <ul style="list-style-type: none"> - an employee of the employer - a representative of an authorised intermediary - a representative of the Designated Group Employer, where the employer is an Ordinary Member of the group. § SRO VIC have created a blank Annual Reconciliation (in effect the obligation) for the period and have not ceased the Annual Reconciliation § The List Outstanding Obligations service has been executed to retrieve the relevant start and end dates to be included in the context of the request message, and, the List Historic Returns service has been executed for re-lodgements.
Post-conditions	Success – The user will receive SRO VIC data to assist in preparation of the Annual Reconciliation. Failure – The User will receive an Error message.
Initiating party	Business
Channel	SBR
Core Service Map	Pre-Fill

5.5.1 Pre-fill Annual Reconciliation Request - Message

5.5.1.1 Discoverable Taxonomy Set References

Schema	ptarvic.0001.prefill.request. 02-00.report.xsd 02.01.report.xsd
Linkbases	ptarvic.0001.prefill.request. 02-00-presLink.xml 02.01.presLink.xml

	ptarvic.0001. prefill.request. 02.00.labLinkInfoCls.xml 02.01.labLinkInfoCls.xml
	ptarvic.0001. prefill.request. 02.00.defLink.xml 02.01.defLink.xml
	ptarvic.0001. prefill.request. 02.00.refLink.xml 02.01.refLink.xml
Example Instance	N/A
Schematron	N/A

5.5.1.1 Standard Business Document Header Content

The WIG provides the specification of the SBDH. The following table specifies the message specific data element values or any variations to the WIG.

Attribute Name	Instructions / Rules	Rule Imp	SBR Msg code
sbdm:Message.Type.Text	1. Mandatory - Value must be "ptarvic.0001.prefill.request"	1. MIG	1. SBR.GEN.GEN.4

5.5.1.2 Standard Business Document Body Content

The following describes the facts and context that must be supplied within the XBRL instance document populated into the SBDB element BusinessDocument.instance.text

5.5.1.2.1 Pre-fill Annual Reconciliation Request XBRL Context

Context Spec	Hypercube Name	Associated Segment Dimensions	Instructions / Rules	Rule Imp	SBR Msg code
ReportingParty	VICReportingPartyReportingPartyVIC	ReportPartyType, AustralianStatesTerritoriesAndOffShoreAreas	<ol style="list-style-type: none"> 1. There must be only one Context within the instance document. 2. The Start Date must be set to the start date relevant to the annual reconciliation as supplied by the List Outstanding Obligations service. Note for a re-lodgement the start date must be set to the start date relevant to the annual reconciliation as supplied by the List Historic Returns service. 3. The End Date must be set to the end date relevant to the annual reconciliation as supplied by the List Outstanding Obligations service. Note for a re-lodgement the end date must be set to the end date relevant to the annual reconciliation as supplied by the List Historic Returns service. 	<ol style="list-style-type: none"> 1. MIG 2. MIG 3. MIG 	<ol style="list-style-type: none"> 1. SBR.GEN.GEN.19 2. SBR.GEN.GEN.18 3. SBR.GEN.GEN.20

5.5.1.2.2 Pre-fill Annual Reconciliation Request Message Content Table

The following table contains the facts required in the instance document.

Context - Reporting Party				
Seq. No.	XBRL Fact	Instructions / Rules	Rule Imp.	SBR Msg Code
1.	Period.Unique.Identifier	1. Mandatory 2. As supplied by either List service.	1. MIG 2. MIG	1. VIC.SRO.GEN.2 2. VIC.SRO.PTX.28

5.5.2 Pre-fill Annual Reconciliation Response - Message

5.5.2.1 Discoverable Taxonomy Set References

Schema	ptarvic.0001.prefill.response. 02.00.report.xsd 02.01.report.xsd
Linkbases	ptarvic.0001.prefill.response. 02.00.presLink.xml 02.01.presLink.xml
	ptarvic.0001.prefill.response. 02.00.labLinkInfoCls.xml 02.01.labLinkInfoCls.xml
	ptarvic.0001.prefill.response. 02.00.defLink.xml 02.01.defLink.xml
	ptarvic.0001.prefill.response. 02.00.refLink.xml 02.01.refLink.xml
Example Instance	N/A

5.5.2.2 Standard Business Document Header Content

The WIG provides the specification of the SBDH. The following table specifies the message specific data element values or any variations to the WIG.

Attribute Name	Instructions / Rules
sbdm:Message.Type.Text	1. Mandatory - Value must be "ptarvic.0001.prefill.response"

5.5.2.3 Standard Business Document Body Content

The following describes the facts and context required to be supplied within the XBRL instance document populated into the SBDB element BusinessDocument.instance.text

5.5.2.3.1 Pre-fill Annual Reconciliation Response XBRL Context

Context Spec	Hypercube Name	Associated Segment Dimensions	Instructions / Rules
ReportingParty	VICReportingPartyReportingPartyVIC	ReportPartyType, AustralianStatesTerritoriesAndOffShoreAreas	1. There will be only one Context of this type within the instance document. 2. The Start Date will be set to the Australian start date relevant to the ABN. 3. The End Date will be set to the Australian end date relevant to the ABN.
Non Group Employer (NGE)	EmpGrpStsVICReportingParty4ReportingPartyVICGroupStructure	ReportPartyType, AustralianStatesTerritoriesAndOffShoreAreas, EmployerGroupStatus	1. There will be zero to one of this context. 2. The Start Date will be set to the Australian start date relevant to the ABN. 3. The End Date will be set to the Australian end date relevant to the ABN.
Designated Group Employer (DGE)	EmpGrpStsVICReportingParty4ReportingPartyVICGroupStructure	ReportPartyType, AustralianStatesTerritoriesAndOffShoreAreas, EmployerGroupStatus	1. There will be zero to one of this context. 2. The Start Date will be set to the Australian start date relevant to the ABN. 3. The End Date will be set to the Australian end date relevant to the ABN.
Designated Group Employer of a Scheduled Group (DGESG)	EmpGrpStsVICReportingParty4ReportingPartyVICGroupStructure	ReportPartyType, AustralianStatesTerritoriesAndOffShoreAreas, EmployerGroupStatus	1. There will be zero to one of this context. 2. The Start Date will be set to the Australian start date relevant to the ABN. 3. The End Date will be set to the Australian end date relevant to the ABN.
Designated Group Employer of a Non Scheduled Group (DGENSG)	EmpGrpStsVICReportingParty4ReportingPartyVICGroupStructure	ReportPartyType, AustralianStatesTerritoriesAndOffShoreAreas, EmployerGroupStatus	1. There will be zero to one of this context. 2. The Start Date will be set to the Australian start date relevant to the ABN. 3. The End Date will be set to the Australian end date relevant to the ABN.
Ordinary Scheduled Member of a Scheduled Group (OSM)	1. EmpGrpStsVICReportingParty4ReportingPartyVICGroupStructure 2. OSMOMGVICReportingPartyReportingPartyVICOMGOSM	ReportPartyType, AustralianStatesTerritoriesAndOffShoreAreas, EmployerGroupStatus	1. There will be zero to many of this context. 2. The Start Date will be set to the Australian start date relevant to the ABN. 3. The End Date will be set to the Australian end date relevant to the ABN.
Ordinary Member of a Scheduled or Non Scheduled Group (OMG)	1. EmpGrpStsVICReportingParty4ReportingPartyVICGroupStructure 2. OSMOMGVICReportingPartyReportingPartyVICOMGOSM 3. OMGVICReportingPartyReportingPartyVICOMG	ReportPartyType, AustralianStatesTerritoriesAndOffShoreAreas, EmployerGroupStatus	1. There will be zero to many of this context. 2. The Start Date will be set to the Australian start date relevant to the ABN. 3. The End Date will be set to the Australian end date relevant to the ABN.
Ordinary Member of a Scheduled or Non Scheduled Group (OM)	EmpGrpStsVICReportingParty4ReportingPartyVICGroupStructure	ReportPartyType, AustralianStatesTerritoriesAndOffShoreAreas, EmployerGroupStatus	1. There will be zero to one of this context. 2. The Start Date will be set to the Australian start date relevant to the ABN. 3. The End Date will be set to the Australian end date relevant to the ABN.

Context structure within instance document:

ReportingParty.EmployerGroupStatus value	Other context to report
NGE	No other contexts to be provided
DGESG	One DGE, Zero to many OSM and Zero to many OMG
DGENSG	One DGE and Zero to many OMG

OM	No other contexts to be provided
----	----------------------------------

5.5.2.3.2 Pre-fill Annual Reconciliation Response Message Content Table

The following table contains the facts required in the instance document.

Context - Reporting Party		
Seq. No.	XBRL Fact	Instructions / Rules
1.	OrganisationNameDetails (Tuple: one only)	
1.1.	OrganisationNameDetails.OrganisationalNameType.Code	1.Mandatory Set to 'MN'
1.2.	OrganisationNameDetails.OrganisationalName.Text	1.Mandatory
2.	Identifiers.StateRevenueOfficeClientNumber.Identifier	1.Mandatory
3.	Identifiers.PayrollTaxGroup.Identifier	1. Conditional. Mandatory, if EmployerGroupStatus (from the ReportingParty.EmployerGroupStatus context) is one of DGESG, DGENSG or OM
4.	PayrollTaxPayment (Tuple: zero to many)	
4.1.	PayrollTax.PaymentAmountReceipt.Date	1.Mandatory Note; information message SRO.VIC.PTX.72 will be returned, when the amount is part of a larger payment
4.2.	PayrollTax.AssessedLiabilitiesPaid.Amount	1.Mandatory Note; information message SRO.VIC.PTX.72 will be returned, when the amount is part of a larger payment
5.	PersonNameDetails (Tuple: zero to one)	Will not be supplied when a device credential is used.
5.1.	PersonNameDetails.PersonNameType.Code	1. Mandatory. Use enumeration 'CNT' - Contact
5.2.	PersonNameDetails.CurrencyCode	Not required by SRO VIC
5.3.	PersonNameDetails.FamilyName.Text	1.Mandatory
5.4.	PersonNameDetails.GivenName.Text	1.Mandatory
5.5.	PersonNameDetails.OtherGivenName.Text	Not required by SRO VIC
6.	ElectronicContactElectronicMail (Tuple: zero to one)	Will not be supplied when a device credential is used.
6.1.	ElectronicContact.ElectronicMail.Usage.Code	1.Mandatory Use enumeration '02' - Business
6.2.	ElectronicContact.ElectronicMail.Address.Text	1.Mandatory
7.	PayrollTax.Deduction.LiabilityExclusion.Indicator	1.Conditional. Mandatory if customer's Deduction Denied indicator (at SRO VIC) is set to true.

Context – Non Group Employer (NGE)		
Seq. No.	XBRL Fact	Instructions / Rules

Context – Non Group Employer (NGE)		
Seq. No.	XBRL Fact	Instructions / Rules
1.	PeriodDetails (Tuple: one only)	
1.1.	Period.Type.Code	1.Mandatory Set to "StateReconciliation"
1.2.	Period.Start.Date	1.Mandatory
1.3.	Period.End.Date	1.Mandatory
2.	PeriodDetails (Tuple: zero to one)	Only supplied for Victorian interstate employers
2.1.	Period.Type.Code	1.Mandatory Set to "InterstateReconciliation "
2.2.	Period.Start.Date	1.Mandatory
2.3.	Period.End.Date	1.Mandatory

Context – Designated Group Employer of a Scheduled Group (DGESG)		
Seq. No.	XBRL Fact	Instructions / Rules
1.	PeriodDetails (Tuple: one only)	
1.1.	Period.Type.Code	1.Mandatory Set to "StateReconciliation"
1.2.	Period.Start.Date	1.Mandatory
1.3.	Period.End.Date	1.Mandatory
2.	PeriodDetails (Tuple: zero to one)	Only supplied for Victorian interstate groups
2.1.	Period.Type.Code	1.Mandatory Set to "InterstateReconciliation "
2.2.	Period.Start.Date	1.Mandatory
2.3.	Period.End.Date	1.Mandatory

Context – Designated Group Employer (DGE)		
Seq. No.	XBRL Fact	Instructions / Rules
1.	PeriodDetails (Tuple: one only)	
1.1.	Period.Type.Code	1.Mandatory Set to "StateReconciliation"
1.2.	Period.Start.Date	1.Mandatory
1.3.	Period.End.Date	1.Mandatory

Context – Designated Group Employer (DGE)		
Seq. No.	XBRL Fact	Instructions / Rules
2.	PeriodDetails (Tuple: zero to one)	Only supplied for Victorian interstate employers
2.1.	Period.Type.Code	1.Mandatory Set to "InterstateReconciliation "
2.2.	Period.Start.Date	1.Mandatory
2.3.	Period.End.Date	1.Mandatory

Context – Ordinary Scheduled Member of a Scheduled Group (OSM)		
Seq. No.	XBRL Fact	Instructions / Rules
1.	Identifiers.StateRevenueOfficeClientNumber.Identifier	1.Mandatory
2.	OrganisationNameDetails (Tuple: one only)	
2.1.	OrganisationNameDetails.OrganisationalNameType.Code	1.Mandatory Set to 'MN'
2.2.	OrganisationNameDetails.OrganisationalName.Text	1.Mandatory
3.	PeriodDetails (Tuple: one only)	
3.1.	Period.Type.Code	1.Mandatory Set to "StateReconciliation"
3.2.	Period.Start.Date	1.Mandatory
3.3.	Period.End.Date	1.Mandatory
4.	PeriodDetails (Tuple: zero to one)	Only supplied for Victorian interstate employers
4.1.	Period.Type.Code	1.Mandatory Set to "InterstateReconciliation "
4.2.	Period.Start.Date	1.Mandatory
4.3.	Period.End.Date	1.Mandatory

Context – Ordinary Member of a Scheduled or Non Scheduled Group (OMG)		
Seq. No.	XBRL Fact	Instructions / Rules
1.	Identifiers.StateRevenueOfficeClientNumber.Identifier	1.Mandatory
2.	OrganisationNameDetails (Tuple: one only)	
2.1.	OrganisationNameDetails.OrganisationalNameType.Code	1.Mandatory Set to 'MN'
2.2.	OrganisationNameDetails.OrganisationalName.Text	1.Mandatory

Context – Ordinary Member of a Scheduled or Non Scheduled Group (OMG)		
Seq. No.	XBRL Fact	Instructions / Rules
3.	PeriodDetails (Tuple: one only)	
3.1.	Period.Type.Code	1.Mandatory Set to "StateReconciliation"
3.2.	Period.Start.Date	1.Mandatory
3.3.	Period.End.Date	1.Mandatory
4.	PeriodDetails (Tuple: zero to one)	Only supplied for Victorian interstate employers
4.1.	Period.Type.Code	1.Mandatory Set to "InterstateReconciliation "
4.2.	Period.Start.Date	1.Mandatory
4.3.	Period.End.Date	1.Mandatory
5.	Remuneration.WagesAndSalaries.TaxableStateTotal.Amount	1.Conditional. Mandatory if OM has provided consent when lodging their own Annual Reconciliation to display their details to the DGE.
6.	Remuneration.WagesAndSalaries.TaxableInterstateTotal.Amount	1. Conditional. Mandatory if OM has provided consent when lodging their own Annual Reconciliation to display their details to the DGE.
7.	PayrollTaxPayment (Tuple: zero to one)	
7.1.	PayrollTax.PaymentAmountReceipt.Date	Not required by SRO VIC
7.2.	PayrollTax.AssessedLiabilitiesPaid.Amount	1. Conditional. Mandatory if OM has provided consent when lodging their own Annual Reconciliation to display their details to the DGE.

Context – Designated Group Employer of a Non Scheduled Group (DGNSG)		
Seq. No.	XBRL Fact	Instructions / Rules
1.	PeriodDetails (Tuple: one only)	
1.1.	Period.Type.Code	1.Mandatory Set to "StateReconciliation"
1.2.	Period.Start.Date	1.Mandatory
1.3.	Period.End.Date	1.Mandatory
2.	PeriodDetails (Tuple: zero to one)	Only supplied for Victorian interstate groups
2.1.	Period.Type.Code	1.Mandatory Set to "InterstateReconciliation "
2.2.	Period.Start.Date	1.Mandatory
2.3.	Period.End.Date	1.Mandatory

Context – Ordinary Member of a Scheduled or Non Scheduled Group (OM)

Seq. No.	XBRL Fact	Instructions / Rules
1.	PeriodDetails (Tuple: one only)	
1.1.	Period.Type.Code	1.Mandatory Set to "StateReconciliation"
1.2.	Period.Start.Date	1.Mandatory
1.3.	Period.End.Date	1.Mandatory
2.	PeriodDetails (Tuple: zero to one)	Only supplied for Victorian interstate employers
2.1.	Period.Type.Code	1.Mandatory Set to "InterstateReconciliation "
2.2.	Period.Start.Date	1.Mandatory
2.3.	Period.End.Date	1.Mandatory

5.6 CALCULATE ANNUAL RECONCILIATION SPECIFICATIONS

Interaction Name	Calculate Annual Reconciliation
Description	<p>The purpose of this interaction is as follows:</p> <ul style="list-style-type: none"> § to enable businesses to request SRO VIC data to assist in completing their Annual Reconciliation, including VIC predetermined deduction amount and employer details, and § to enable businesses to request the SRO VIC calculated tax liability amount for review prior to lodgement. <p>This service can be called multiple times.</p>
Stakeholders	Business, State Revenue Offices and Intermediaries
Pre-conditions	<ul style="list-style-type: none"> § Employer is registered for payroll tax in the State of Victoria § Employer has activated their SRO VIC customer record for SBR access via SRO VIC's portal application PTX Express § User has been authenticated via the VANguard Security Token Service (and the token is still valid). This token is valid across multiple transactions (until it expires). § Employer record details held by SRO VIC are accurate and up to date § User is authorised to lodge payroll tax on behalf of the employer, as: <ul style="list-style-type: none"> - an employee of the employer - a representative of an authorised intermediary - a representative of the Designated Group Employer, where the employer is an Ordinary Member of the group. § SRO VIC have created a blank Reconciliation (in effect the obligation) for the period and have not ceased the Reconciliation § Pre-fill service has been executed successfully
Post-conditions	<p>Success – The user will receive SRO VIC data to assist in preparation of the Reconciliation and, if wages or tax figures were provided in the request, the payroll tax liability.</p> <p>Failure – The User will receive an Error message.</p>

Initiating party	Business
Channel	SBR
Core Service Map	Pre-Lodge

5.6.1 Calculate Annual Reconciliation Request - Message

5.6.1.1 Discoverable Taxonomy Set References

Schema	ptarvic.0001.calculate.request. 02.00.report.xsd 02.01.report.xsd
Linkbases	ptarvic.0001.calculate.request. 02.00.presLink.xml 02.01.presLink.xml
	ptarvic.0001.calculate.request. 02.00.labLinkInfoCls.xml 02.01.labLinkInfoCls.xml
	ptarvic.0001.calculate.request. 02.00.defLink.xml 02.01.defLink.xml
	ptarvic.0001.calculate.request. 02.00.refLink.xml 02.01.refLink.xml
Example Instance	N/A
Schematron	N/A ptarvic.0001.calculate.request.02.00.sch

5.6.1.2 Standard Business Document Header Content

The WIG provides the specification of the SBDH. The following table specifies the message specific data element values or any variations to the WIG.

Attribute Name	Instructions / Rules	Rule Imp	SBR Msg code
sbdm:Message.Type.Text	1. Mandatory - Value must be "ptarvic.0001.calculate.request"	1. MIG	1. SBR.GEN.GEN.4

5.6.1.3 Standard Business Document Body Content

The following describes the facts and context that must be supplied within the XBRL instance document populated into the SBDB element BusinessDocument.instance.text

5.6.1.3.1 Calculate Annual Reconciliation Request XBRL Context

Context Spec	Hypercube Name	Associated Segment Dimensions	Instructions / Rules	Rule Imp	SBR Msg code
ReportingParty	VICReportingPartyReportingPartyVIC	ReportPartyType, AustralianStatesTerritoriesAndOffShoreAreas	<ol style="list-style-type: none"> 1. There must be only one Context within the instance document. 2. The Start Date must be set to the start date relevant to the Annual Reconciliation. This date is provided in the pre-fill request. 3. The End Date must be set to the end date relevant to the Annual Reconciliation. This date is provided in the pre-fill request. 	<ol style="list-style-type: none"> 1. MIG 2. MIG 3. MIG 	<ol style="list-style-type: none"> 1. SBR.GEN.GEN.19 2. SBR.GEN.GEN.18 3. SBR.GEN.GEN.20
Non Group Employer (NGE)	<ol style="list-style-type: none"> 1. EmpGrpStsVICReportingParty1ReportingPartyVICNGEDGEGOMOSM 2. EmpGrpStsVICReportingParty2ReportingPartyVICOSM(Negative) 	ReportPartyType, AustralianStatesTerritoriesAndOffShoreAreas, EmployerGroupStatus	<ol style="list-style-type: none"> 1. There must be zero to one of this context. 2. ABN must match the value held by SRO VIC. 3. The Start Date must be set to the Australian start date relevant to the ABN. 4. The End Date must be set to the Australian end date relevant to the ABN. 5. EmployerGroupStatus must match the value held by SRO VIC. <p>ABN, Start date, End date and EmployerGroupStatus were all supplied in the pre-fill response.</p>	<ol style="list-style-type: none"> 1. MIG 2. MIG 3. MIG 4. MIG 5. MIG 	<ol style="list-style-type: none"> 1. SBR.GEN.GEN.19 2. VIC.SRO.PTX.36 3. SBR.GEN.GEN.18 4. SBR.GEN.GEN.20 5. VIC.SRO.GEN.50
Designated Group Employer (DGE)	<ol style="list-style-type: none"> 1. EmpGrpStsVICReportingParty1 2. EmpGrpStsVICReportingParty21.ReportingPartyVICNGEDGEGOMOSM2-ReportingPartyVICOSM(Negative) 	ReportPartyType, AustralianStatesTerritoriesAndOffShoreAreas, EmployerGroupStatus	<ol style="list-style-type: none"> 1. There must be zero to one of this context. 2. ABN must match the value held by SRO VIC. 3. The Start Date must be set to the Australian start date relevant to the ABN. 4. The End Date must be set to the Australian end date relevant to the ABN. 5. EmployerGroupStatus must match the value held by SRO VIC. <p>ABN, Start date, End date and EmployerGroupStatus were all supplied in the pre-fill response.</p>	<ol style="list-style-type: none"> 1. MIG 2. MIG 3. MIG 4. MIG 5. MIG 	<ol style="list-style-type: none"> 1. SBR.GEN.GEN.19 2. VIC.SRO.PTX.36 3. SBR.GEN.GEN.18 4. SBR.GEN.GEN.20 5. VIC.SRO.GEN.50

Context Spec	Hypercube Name	Associated Segment Dimensions	Instructions / Rules	Rule Imp	SBR Msg code
Designated Group Employer of a Scheduled Group (DGESG)	1. DGESGDGENSG VICReportingParty ReportingPartyVIC DGESGDGENSG	ReportPartyType, AustralianStatesTerritoriesAndOffShoreAreas, EmployerGroupStatus	1. There must be zero to one of this context. 2. ABN must match the value held by SRO VIC. 3. The Start Date must be set to the Australian start date relevant to the ABN. 4. The End Date must be set to the Australian end date relevant to the ABN. 5. EmployerGroupStatus must match the value held by SRO VIC. ABN, Start date, End date and EmployerGroupStatus were all supplied in the pre-fill response.	1. MIG 2. MIG 3. MIG 4. MIG 5. MIG	1. SBR.GEN.GEN.19 2. VIC.SRO.PTX.36 3. SBR.GEN.GEN.18 4. SBR.GEN.GEN.20 5. VIC.SRO.GEN.50
Designated Group Employer of a Non Scheduled Group (DGENSG)	1. DGESGDGENSG VICReportingParty ReportingPartyVIC DGESGDGENSG	ReportPartyType, AustralianStatesTerritoriesAndOffShoreAreas, EmployerGroupStatus	1. There must be zero to one of this context. 2. ABN must match the value held by SRO VIC. 3. The Start Date must be set to the Australian start date relevant to the ABN. 4. The End Date must be set to the Australian end date relevant to the ABN. 5. EmployerGroupStatus must match the value held by SRO VIC. ABN, Start date, End date and EmployerGroupStatus were all supplied in the pre-fill response.	1. MIG 2. MIG 3. MIG 4. MIG 5. MIG	1. SBR.GEN.GEN.19 2. VIC.SRO.PTX.36 3. SBR.GEN.GEN.18 4. SBR.GEN.GEN.20 5. VIC.SRO.GEN.50
Ordinary Scheduled Member of a Scheduled Group (OSM)	1. EmpGrpStsVICRe portingParty1Re portingPartyVICNGE DGEOMOSM 2- ReportingPartyV ICOSM (Negative)	ReportPartyType, AustralianStatesTerritoriesAndOffShoreAreas, EmployerGroupStatus	1. There must be zero to many of this context. 2. ABN must match the value held by SRO VIC. 3. The Start Date must be set to the Australian start date relevant to the ABN. 4. The End Date must be set to the Australian end date relevant to the ABN. 5. EmployerGroupStatus must match the value held by SRO VIC. ABN, Start date, End date and EmployerGroupStatus were all supplied in the pre-fill response.	1. MIG 2. MIG 3. MIG 4. MIG 5. MIG	1. SBR.GEN.GEN.19 2. VIC.SRO.PTX.36 3. SBR.GEN.GEN.18 4. SBR.GEN.GEN.20 5. VIC.SRO.GEN.50
Ordinary Member of a Scheduled or Non Scheduled Group (OM)	1. EmpGrpStsVICRe portingParty1 2. EmpGrpStsVICRe portingParty24.Re portingPartyVICN GEDGEMOSM 2- ReportingPartyV ICOSM (Negative)	ReportPartyType, AustralianStatesTerritoriesAndOffShoreAreas, EmployerGroupStatus	1. There must be zero to one of this context. 2. ABN must match the value held by SRO VIC. 3. The Start Date must be set to the Australian start date relevant to the ABN. 4. The End Date must be set to the Australian end date relevant to the ABN. 5. EmployerGroupStatus must match the value held by SRO VIC. ABN, Start date, End date and EmployerGroupStatus were all supplied in the pre-fill response.	1. MIG 2. MIG 3. MIG 4. MIG 5. MIG	1. SBR.GEN.GEN.19 2. VIC.SRO.PTX.36 3. SBR.GEN.GEN.18 4. SBR.GEN.GEN.20 5. VIC.SRO.GEN.50

Context structure within instance document:

ReportingParty.EmployerGroupStatus value	Other context to report
NGE	No other contexts to be provided
DGESG	One DGE and Zero to many OSM
DGENSG	One DGE
OM	No other contexts to be provided

5.6.1.3.2 Calculate Annual Reconciliation Request Message Content Table

The following table contains the facts required in the instance document.

Where 'taxable wages' are referenced in the rules, this should be interpreted as comprising the following elements:

§ Remuneration.WagesandSalaries.Payments.Amount

§ Remuneration.EmploymentAllowancesIncludingApprenticesAndTrainees.Amount

§ Remuneration.CommissionsAndBonuses.Amount

§ Remuneration.WagesAndSalaries.ContractorsAndConsultantsPayments.Amount

§ Remuneration.Fees.Directors.Amount

§ FringeBenefitsTax.GrossAmountMinusTaxExemptBodyEntertainment.Amount

§ SuperannuationContribution.EmployerContributions.Amount

§ Remuneration.EmploymentTermination.Payments.Amount

§ Remuneration.EmployeeSharesAndOptions.Amount

§ Remuneration.WagesAndSalaries.TaxablePayrollOther.Amount

Context - Reporting Party				
Seq. No.	XBRL Fact	Instructions / Rules	Rule Imp.	SBR Msg Code
1.	Period.Unique.Identifier	1. Mandatory 2. As supplied by either List service.	1. MIG 2. MIG	1. VIC.SRO.GEN.2 2. VIC.SRO.PTX.28
2.—	PayrollTax.Deduction.LiabilityInclusion.Indicator	1. Conditional. Mandatory for NGE, DGESG or DGENSG. 2. Conditional. Not required for OM and where PayrollTax.Deduction.LiabilityExclusion.Indicator (supplied in pre-fill response) is true.	1.MIG 2.MIG	1.VIC.SRO.PTX.31 or VIC.SRO.PTX.64 2.VIC.SRO.PTX.64

Context – Non Group Employer (NGE)

Seq. No.	XBRL Fact	Instructions / Rules	Rule Imp.	SBR Msg Code
1.	Remuneration.WagesAndSalaries.Payments.Amount	1.Mandatory 2. See section 2.6.2 Format Rules, Wage Fields	1. MIG 2. See s2.6.2	1. VIC.SRO.GEN.2 2. See s2.6.2
2.	Remuneration.EmploymentAllowancesIncludingApprenticesAndTrainees.Amount	1. Mandatory 2. See section 2.6.2 Format Rules, Wage Fields	1. MIG 2. See s2.6.2	1. VIC.SRO.GEN.2 2. See s2.6.2
3.	Remuneration.CommissionsAndBonuses.Amount	1. Mandatory 2. See section 2.6.2 Format Rules, Wage Fields	1. MIG 2. See s2.6.2	1. VIC.SRO.GEN.2 2. See s2.6.2
4.	Remuneration.WagesAndSalaries.ContractorsAndConsultantsPayments.Amount	1. Mandatory 2. See section 2.6.2 Format Rules, Wage Fields	1. MIG 2. See s2.6.2	1. VIC.SRO.GEN.2 2. See s2.6.2
5.	Remuneration.Fees.Directors.Amount	1. Mandatory 2. See section 2.6.2 Format Rules, Wage Fields	1. MIG 2. See s2.6.2	1. VIC.SRO.GEN.2 2. See s2.6.2
6.	FringeBenefitsTax.GrossAmountMinusTaxExemptBodyEntertainment.Amount	1. Mandatory 2. See section 2.6.2 Format Rules, Wage Fields	1. MIG 2. See s2.6.2	1. VIC.SRO.GEN.2 2. See s2.6.2
7.	SuperannuationContribution.EmployerContributions.Amount	1. Mandatory 2. See section 2.6.2 Format Rules, Wage Fields 3. Warning issued if less than 9%	1. MIG 2. See s2.6.2 3. MIG	1. VIC.SRO.GEN.2 2. See s2.6.2 3. VIC.SRO.PTX.55
8.	Remuneration.EmploymentTermination.Payments.Amount	1. Mandatory 2. See section 2.6.2 Format Rules, Wage Fields	1. MIG 2. See s2.6.2	1. VIC.SRO.GEN.2 2. See s2.6.2
9.	Remuneration.EmployeeSharesAndOptions.Amount	1. Mandatory 2. See section 2.6.2 Format Rules, Wage Fields	1. MIG 2. See s2.6.2	1. VIC.SRO.GEN.2 2. See s2.6.2
10.	Remuneration.WagesAndSalaries.SharesAndOptionsOffset.Amount	1.Mandatory 2. See section 2.6.2 Format Rules, Wage Fields 3. The value cannot exceed the total of the taxable wages	1. MIG 2. See s2.6.2 3. MIG	1. VIC.SRO.GEN.2 2. See s2.6.2 3. VIC.SRO.PTX.68
11.	Remuneration.WagesAndSalaries.TaxablePayrollOther.Amount	1. Mandatory 2. See section 2.6.2 Format Rules, Wage Fields	1. MIG 2. See s2.6.2	1. VIC.SRO.GEN.2 2. See s2.6.2

Context – Non Group Employer (NGE)				
Seq. No.	XBRL Fact	Instructions / Rules	Rule Imp.	SBR Msg Code
12.	Remuneration.WagesAndSalaries.TaxableInterstateTotal.Amount	1.Conditional. Mandatory if employs interstate, see section 4.2.4 Employs Interstate. 2. See section 2.6.2 Format Rules, Wage Fields	1. MIG 2. See s2.6.2	1. VIC.SRO.PTX.42 or VIC.SRO.PTX.64 2. See s2.6.2
13.	PayrollTax.TotalPaymentsMadeForAnnualPeriod.Amount	1.Mandatory 2. See section 2.6.2 Format Rules, Payment Fields	1. MIG 2. See s2.6.2	1. VIC.SRO.GEN.2 2. See s2.6.2

Context – Designated Group Employer of a Scheduled Group (DGESG)				
Seq. No.	XBRL Fact	Instructions / Rules	Rule Imp.	SBR Msg Code
1.	Remuneration.WagesAndSalaries.TotalOrdinaryMembersGrossTaxableVictorianWages.Amount	1.Mandatory 2. See section 2.6.2 Format Rules, Wage Fields	1. MIG 2. See s2.6.2	1. VIC.SRO.PTX.32 2. See s2.6.2
2.	Remuneration.WagesAndSalaries.InterstateOnlyMembersGrossTaxableInterstateWages.Amount	1.Conditional. Mandatory if group employs interstate. 2. See section 2.6.2 Format Rules, Wage Fields	1. MIG 2. See s2.6.2	1. VIC.SRO.PTX.43 or VIC.SRO.PTX.64 2. See s2.6.2
3.	Remuneration.WagesAndSalaries.TotalOrdinaryMembersGrossTaxableInterstateWages.Amount	1.Conditional. Mandatory if group employs interstate. 2. See section 2.6.2 Format Rules, Wage Fields	1. MIG 2. See s2.6.2	1. VIC.SRO.PTX.43 or VIC.SRO.PTX.64 2. See s2.6.2
4.	PaymentRecord.TotalPaymentsReceivedByAllOrdinaryMembers.Amount	1.Mandatory 2. See section 2.6.2 Format Rules, Payment Fields	1. MIG 2. See s2.6.2	1. VIC.SRO.PTX.32 2. See s2.6.2

Context – Designated Group Employer (DGE)				
Seq. No.	XBRL Fact	Instructions / Rules	Rule Imp.	SBR Msg Code
1.	Remuneration.WagesAndSalaries.Payments.Amount	1.Mandatory 2. See section 2.6.2 Format Rules, Wage Fields	1. MIG 2. See s2.6.2	1. VIC.SRO.GEN.2 2. See s2.6.2
2.	Remuneration.EmploymentAllowancesIncludingApprenticesAndTrainees.Amount	1. Mandatory 2. See section 2.6.2 Format Rules, Wage Fields	1. MIG 2. See s2.6.2	1. VIC.SRO.GEN.2 2. See s2.6.2
3.	Remuneration.CommissionsAndBonuses.Amount	1. Mandatory 2. See section 2.6.2 Format Rules, Wage Fields	1. MIG 2. See s2.6.2	1. VIC.SRO.GEN.2 2. See s2.6.2
4.	Remuneration.WagesAndSalaries.ContractorsAndConsultantsPayments.Amount	1. Mandatory 2. See section 2.6.2 Format Rules, Wage Fields	1. MIG 2. See s2.6.2	1. VIC.SRO.GEN.2 2. See s2.6.2
5.	Remuneration.Fees.Directors.Amount	1. Mandatory 2. See section 2.6.2 Format Rules, Wage Fields	1. MIG 2. See s2.6.2	1. VIC.SRO.GEN.2 2. See s2.6.2
6.	FringeBenefitsTax.GrossAmountMinusTaxExemptBodyEntertainment.Amount	1. Mandatory 2. See section 2.6.2 Format Rules, Wage Fields	1. MIG 2. See s2.6.2	1. VIC.SRO.GEN.2 2. See s2.6.2
7.	SuperannuationContribution.EmployerContributions.Amount	1. Mandatory 2. See section 2.6.2 Format Rules, Wage Fields 3. Warning issued if less than 9%	1. MIG 2. See s2.6.2 3. MIG	1. VIC.SRO.GEN.2 2. See s2.6.2 3. VIC.SRO.PTX.55
8.	Remuneration.EmploymentTermination.Payments.Amount	1. Mandatory 2. See section 2.6.2 Format Rules, Wage Fields	1. MIG 2. See s2.6.2	1. VIC.SRO.GEN.2 2. See s2.6.2
9.	Remuneration.EmployeeSharesAndOptions.Amount	1. Mandatory 2. See section 2.6.2 Format Rules, Wage Fields	1. MIG 2. See s2.6.2	1. VIC.SRO.GEN.2 2. See s2.6.2
10.	Remuneration.WagesAndSalaries.SharesAndOptionsOffset.Amount	1.Mandatory 2. See section 2.6.2 Format Rules, Wage Fields 3. The value cannot exceed the total of the taxable wages	1. MIG 2. See s2.6.2 3. MIG	1. VIC.SRO.GEN.2 2. See s2.6.2 3. VIC.SRO.PTX.68
11.	Remuneration.WagesAndSalaries.TaxablePayrollOther.Amo	1. Mandatory 2. See section 2.6.2 Format Rules, Wage Fields	1. MIG	1. VIC.SRO.GEN.2

Context – Designated Group Employer (DGE)				
Seq. No.	XBRL Fact	Instructions / Rules	Rule Imp.	SBR Msg Code
	unt		2. See s2.6.2	2. See s2.6.2
12.	Remuneration.WagesAndSalaries.TaxableInterstateTotal.Amount	1. Conditional. Mandatory if employs interstate, see section 4.2.4 Employs Interstate. 2. See section 2.6.2 Format Rules, Wage Fields	1. MIG 2. See s2.6.2	1. VIC.SRO.PTX.42 or VIC.SRO.PTX.64 2. See s2.6.2
13.	PayrollTax.TotalPaymentsMadeForAnnualPeriod.Amount	1.Mandatory 2. See section 2.6.2 Format Rules, Payment Fields	1. MIG 2. See s2.6.2	1. VIC.SRO.GEN.2 2. See s2.6.2

Context – Ordinary Scheduled Member of a Scheduled Group (OSM)				
Seq. No.	XBRL Fact	Instructions / Rules	Rule Imp.	SBR Msg Code
1.	Remuneration.WagesAndSalaries.Payments.Amount	1. Mandatory 2. See section 2.6.2 Format Rules, Wage Fields	1. MIG 2. See s2.6.2	1. VIC.SRO.GEN.2 2. See s2.6.2
2.	Remuneration.EmploymentAllowancesIncludingApprenticesAndTrainees.Amount	1. Mandatory 2. See section 2.6.2 Format Rules, Wage Fields	1. MIG 2. See s2.6.2	1. VIC.SRO.GEN.2 2. See s2.6.2
3.	Remuneration.CommissionsAndBonuses.Amount	1. Mandatory 2. See section 2.6.2 Format Rules, Wage Fields	1. MIG 2. See s2.6.2	1. VIC.SRO.GEN.2 2. See s2.6.2
4.	Remuneration.WagesAndSalaries.ContractorsAndConsultantsPayments.Amount	1. Mandatory 2. See section 2.6.2 Format Rules, Wage Fields	1. MIG 2. See s2.6.2	1. VIC.SRO.GEN.2 2. See s2.6.2
5.	Remuneration.Fees.Directors.Amount	1. Mandatory 2. See section 2.6.2 Format Rules, Wage Fields	1. MIG 2. See s2.6.2	1. VIC.SRO.GEN.2 2. See s2.6.2
6.	FringeBenefitsTax.GrossAmountMinusTaxExemptBodyEntertainment.Amount	1. Mandatory 2. See section 2.6.2 Format Rules, Wage Fields	1. MIG 2. See s2.6.2	1. VIC.SRO.GEN.2 2. See s2.6.2

Context – Ordinary Scheduled Member of a Scheduled Group (OSM)				
Seq. No.	XBRL Fact	Instructions / Rules	Rule Imp.	SBR Msg Code
7.	SuperannuationContribution.EmployerContributions.Amount	1. Mandatory 2. See section 2.6.2 Format Rules, Wage Fields 3. Warning issued if less than 9%	1. MIG 2. See s2.6.2 3. MIG	1. VIC.SRO.GEN.2 2. See s2.6.2 3. VIC.SRO.PTX.55
8.	Remuneration.EmploymentTermination.Payments.Amount	1. Mandatory 2. See section 2.6.2 Format Rules, Wage Fields	1. MIG 2. See s2.6.2	1. VIC.SRO.GEN.2 2. See s2.6.2
9.	Remuneration.EmployeeSharesAndOptions.Amount	1. Mandatory 2. See section 2.6.2 Format Rules, Wage Fields	1. MIG 2. See s2.6.2	1. VIC.SRO.GEN.2 2. See s2.6.2
10.	Remuneration.WagesAndSalaries.SharesAndOptionsOffset.Amount	1. Mandatory 2. See section 2.6.2 Format Rules, Wage Fields 3. The value cannot exceed the total of the taxable wages	1. MIG 2. See s2.6.2 3. MIG	1. VIC.SRO.GEN.2 2. See s2.6.2 3. VIC.SRO.PTX.68
11.	Remuneration.WagesAndSalaries.TaxablePayrollOther.Amount	1. Mandatory 2. See section 2.6.2 Format Rules, Wage Fields	1. MIG 2. See s2.6.2	1. VIC.SRO.GEN.2 2. See s2.6.2
12.	Remuneration.WagesAndSalaries.TaxableInterstateTotal.Amount	1. Conditional. Mandatory if employs interstate, see section 4.2.4 Employs Interstate. 2. See section 2.6.2 Format Rules, Wage Fields	1. MIG 2. See s2.6.2	1. VIC.SRO.PTX.42 or VIC.SRO.PTX.64 2. See s2.6.2

Context – Designated Group Employer of a Non Scheduled Group (DGENSG)				
Seq. No.	XBRL Fact	Instructions / Rules	Rule Imp.	SBR Msg Code
1.	Remuneration.WagesAndSalaries.TotalOrdinaryMembersGrossTaxableVictorianWages.Amount	1. Mandatory 2. See section 2.6.2 Format Rules, Wage Fields	1. MIG 2. See s2.6.2	1. VIC.SRO.PTX.32 2. See s2.6.2

Context – Designated Group Employer of a Non Scheduled Group (DGENSG)				
Seq. No.	XBRL Fact	Instructions / Rules	Rule Imp.	SBR Msg Code
2.	Remuneration.WagesAndSalaries.InterstateOnlyMembersGrossTaxableInterstateWages.Amount	1.Conditional. Mandatory if group employs interstate, see section 4.2.4 Employs Interstate. 2. See section 2.6.2 Format Rules, Wage Fields	1. MIG 2. See s2.6.2	1. VIC.SRO.PTX.43 or VIC.SRO.PTX.64 2. See s2.6.2
3.	Remuneration.WagesAndSalaries.TotalOrdinaryMembersGrossTaxableInterstateWages.Amount	1. Conditional. Mandatory if group employs interstate, see section 4.2.4 Employs Interstate. 2. See section 2.6.2 Format Rules, Wage Fields	1. MIG 2. See s2.6.2	1. VIC.SRO.PTX.43 or VIC.SRO.PTX.64 2. See s2.6.2
4.	PaymentRecord.TotalPaymentsReceivedByAllOrdinaryMembers.Amount	1.Mandatory 2. See section 2.6.2 Format Rules, Payment Fields	1. MIG 2. See s2.6.2	1. VIC.SRO.PTX.32 2. See s2.6.2

Context – Ordinary Member of a Scheduled or Non Scheduled Group (OM)				
Seq. No.	XBRL Fact	Instructions / Rules	Rule Imp.	SBR Msg Code
1.	Remuneration.WagesAndSalaries.Payments.Amount	1.Mandatory 2. See section 2.6.2 Format Rules, Wage Fields	1. MIG 2. See s2.6.2	1. VIC.SRO.GEN.2 2. See s2.6.2
2.	Remuneration.EmploymentAllowancesIncludingApprentices AndTrainees.Amount	1. Mandatory 2. See section 2.6.2 Format Rules, Wage Fields	1. MIG 2. See s2.6.2	1. VIC.SRO.GEN.2 2. See s2.6.2
3.	Remuneration.CommissionsAndBonuses.Amount	1. Mandatory 2. See section 2.6.2 Format Rules, Wage Fields	1. MIG 2. See s2.6.2	1. VIC.SRO.GEN.2 2. See s2.6.2
4.	Remuneration.WagesAndSalaries.ContractorsAndConsultantsPayments.Amount	1. Mandatory 2. See section 2.6.2 Format Rules, Wage Fields	1. MIG 2. See s2.6.2	1. VIC.SRO.GEN.2 2. See s2.6.2

Context – Ordinary Member of a Scheduled or Non Scheduled Group (OM)				
Seq. No.	XBRL Fact	Instructions / Rules	Rule Imp.	SBR Msg Code
5.	Remuneration.Fees.Directors.Amount	1. Mandatory 2. See section 2.6.2 Format Rules, Wage Fields	1. MIG 2. See s2.6.2	1. VIC.SRO.GEN.2 2. See s2.6.2
6.	FringeBenefitsTax.GrossAmountMinusTaxExemptBodyEntertainment.Amount	1. Mandatory 2. See section 2.6.2 Format Rules, Wage Fields	1. MIG 2. See s2.6.2	1. VIC.SRO.GEN.2 2. See s2.6.2
7.	SuperannuationContribution.EmployerContributions.Amount	1. Mandatory 2. See section 2.6.2 Format Rules, Wage Fields 3. Warning issued if less than 9%	1. MIG 2. See s2.6.2 3. MIG	1. VIC.SRO.GEN.2 2. See s2.6.2 3. VIC.SRO.PTX.55
8.	Remuneration.EmploymentTermination.Payments.Amount	1. Mandatory 2. See section 2.6.2 Format Rules, Wage Fields	1. MIG 2. See s2.6.2	1. VIC.SRO.GEN.2 2. See s2.6.2
9.	Remuneration.EmployeeSharesAndOptions.Amount	1. Mandatory 2. See section 2.6.2 Format Rules, Wage Fields	1. MIG 2. See s2.6.2	1. VIC.SRO.GEN.2 2. See s2.6.2
10.	Remuneration.WagesAndSalaries.SharesAndOptionsOffset.Amount	1. Mandatory 2. See section 2.6.2 Format Rules, Wage Fields 3. The value cannot exceed the total of the taxable wages	1. MIG 2. See s2.6.2 3. MIG	1. VIC.SRO.GEN.2 2. See s2.6.2 3. VIC.SRO.PTX.68
11.	Remuneration.WagesAndSalaries.TaxablePayrollOther.Amount	1. Mandatory 2. See section 2.6.2 Format Rules, Wage Fields	1. MIG 2. See s2.6.2	1. VIC.SRO.GEN.2 2. See s2.6.2
12.	Remuneration.WagesAndSalaries.TaxableInterstateTotal.Amount	1. Conditional. Mandatory if employs interstate, see section 4.2.4 Employs Interstate. 2. See section 2.6.2 Format Rules, Wage Fields	1. MIG 2. See s2.6.2	1. VIC.SRO.PTX.42 2. See s2.6.2
13.	PayrollTax.TotalPaymentsMadeForAnnualPeriod.Amount	1. Mandatory 2. See section 2.6.2 Format Rules, Payment Fields	1. MIG 2. See s2.6.2	1. VIC.SRO.GEN.2 2. See s2.6.2

5.6.2 Calculate Annual Reconciliation Response - Message

5.6.2.1 Discoverable Taxonomy Set References

Schema	ptarvic.0001.calculate.response. 02.00.report.xsd 02.01.report.xsd
Linkbases	ptarvic.0001.calculate.response. 02.00.presLink.xml 02.01.presLink.xml
	ptarvic.0001.calculate.response. 02.00.labLinkInfoCls.xml 02.01.labLinkInfoCls.xml
	ptarvic.0001.calculate.response. 02.00.defLink.xml 02.01.defLink.xml
	ptarvic.0001.calculate.response. 02.00.refLink.xml 02.01.refLink.xml
Example Instance	N/A

5.6.2.2 Standard Business Document Header Content

The WIG provides the specification of the SBDH. The following table specifies the message specific data element values or any variations to the WIG.

Attribute Name	Instructions / Rules
sbdm:Message.Type.Text	1. Mandatory - Value must be "ptarvic.0001.calculate.response"

5.6.2.3 Standard Business Document Body Content

The following describes the facts and context that must be supplied within the XBRL instance document populated into the SBDB element BusinessDocument.instance.text

5.6.2.3.1 Calculate Annual Reconciliation Response XBRL Context

Context Spec	Hypercube Name	Associated Segment Dimensions	Instructions / Rules
ReportingParty	VICReportingPartyReportingPartyVIC	ReportPartyType, AustralianStatesTerritoriesAndOffShoreAreas	1. There will be only one Context within the instance document. 2. The Start Date will be set to the start date relevant to the Annual Reconciliation. 3. The End Date will be set to the end date relevant to the Annual Reconciliation.
Non Group Employer (NGE)	1-EmpGrpStsVICReportingParty1ReportingPartyVICNGEDGEOMO SM	ReportPartyType, AustralianStatesTerritoriesAndOffShoreAreas, EmployerGroupStatus	1. There will be zero to one of this context. 2. The Start Date will be set to the Australian start date relevant to the ABN. 3. The End Date will be set to the Australian end date relevant to the ABN.
Designated Group Employer (DGE)	1-EmpGrpStsVICReportingParty1ReportingPartyVICNGEDGEOMO SM	ReportPartyType, AustralianStatesTerritoriesAndOffShoreAreas, EmployerGroupStatus	1. There will be zero to one of this context. 2. The Start Date will be set to the Australian start date relevant to the ABN. 3. The End Date will be set to the Australian end date relevant to the ABN.
Designated Group Employer of a Scheduled Group (DGESG)	1. DGESGDGENSGVICReportingPartyReportingPartyVICDGESG 2. DGESGVICReportingPartyReportingPartyVICDGESGDGENSG	ReportPartyType, AustralianStatesTerritoriesAndOffShoreAreas, EmployerGroupStatus	1. There will be zero to one of this context. 2. The Start Date will be set to the Australian start date relevant to the ABN. 3. The End Date will be set to the Australian end date relevant to the ABN.
Designated Group Employer of a Non Scheduled Group (DGENSG)	1-DGESGDGENSGVICReportingPartyReportingPartyVICDGESGDGENSG	ReportPartyType, AustralianStatesTerritoriesAndOffShoreAreas, EmployerGroupStatus	1. There will be zero to one of this context. 2. The Start Date will be set to the Australian start date relevant to the ABN. 3. The End Date will be set to the Australian end date relevant to the ABN.
Ordinary Scheduled Member of a Scheduled Group (OSM)	1-EmpGrpStsVICReportingParty1ReportingPartyVICNGEDGEOMO SM	ReportPartyType, AustralianStatesTerritoriesAndOffShoreAreas, EmployerGroupStatus	1. There will be zero to many of this context. 2. The Start Date will be set to the Australian start date relevant to the ABN. 3. The End Date will be set to the Australian end date relevant to the ABN.
Ordinary Member of a Scheduled or Non Scheduled Group (OM)	1-EmpGrpStsVICReportingParty1ReportingPartyVICNGEDGEOMO SM	ReportPartyType, AustralianStatesTerritoriesAndOffShoreAreas, EmployerGroupStatus	1. There will be zero to one of this context. 2. The Start Date will be set to the Australian start date relevant to the ABN. 3. The End Date will be set to the Australian end date relevant to the ABN.
GovernmentAgency	GovernmentAgencyGovernmentAgency	ReportPartyType	1. There will be only one Context within the instance document. 2. The Start Date will be set to the start date relevant to the Annual Reconciliation. 3. The End Date will be set to the end date relevant to the Annual Reconciliation.

Context structure within instance document:

ReportingParty.EmployerGroupStatus value	Other context to report
NGE	No other contexts to be provided
DGESG	One DGE and Zero to many OSM

DGENSG	One DGE
OM	No other contexts to be provided

5.6.2.3.2 Calculate Annual Reconciliation Response Message Content Table

The following table contains the facts required in the instance document. To ensure that the following table is interpreted correctly please Refer to Appendix A for a detailed description of each column.

Context - Reporting Party		
Seq. No.	XBRL Fact	Instructions / Rules
1.	PayrollTax.Deduction.CalculatedTotal.Amount	1. Mandatory
2.	PayrollTax.TaxableCalculated.Amount	1. Mandatory
3.	PayrollTax.PayableTaxCalculated.Amount	1. Mandatory
4.	PayrollTax.AssessedLiabilitiesPaid.Amount	1. Mandatory
5.	PayrollTax.NetTaxPayable.Amount	1. Conditional. Mandatory if PayrollTax.PayableTaxCalculated.Amount >= PayrollTax.AssessedLiabilitiesPaid.Amount
6.	PaymentRecord.EmployerOverpaymentClaimedAsRefund.Amount	1. Conditional. Mandatory if PayrollTax.PayableTaxCalculated.Amount < PayrollTax.AssessedLiabilitiesPaid.Amount
7.	PayrollTax.LiablePeriodEmploymentDays.Count	1.Optional

Context – Non Group Employer (NGE)		
Seq. No.	XBRL Fact	Instructions / Rules
1.	Remuneration.WagesAndSalaries.TaxableStateTotal.Amount	1. Mandatory

Context – Non Group Employer (NGE)		
Seq. No.	XBRL Fact	Instructions / Rules
2.	Remuneration.WagesAndSalaries.TaxableStateAndInterstateTotal.Amount	1.Mandatory

Context – Designated Group Employer of a Scheduled Group (DGESG)		
Seq. No.	XBRL Fact	Instructions / Rules
1.	Remuneration.WagesAndSalaries.TotalOrdinaryScheduledMembersGrossTaxableStateWages.Amount	1.Mandatory
2.	Remuneration.WagesAndSalaries.TotalOrdinaryScheduledMembersGrossTaxableInterstateWages.Amount	1.Mandatory
3.	Remuneration.WagesAndSalaries.TotalOrdinaryScheduledMembersGrossTaxableAustralianWages.Amount	1.Mandatory
4.	Remuneration.WagesAndSalaries.OrdinaryMembersGrossTaxableAustralianWages.Amount	1.Mandatory
5.	Remuneration.WagesAndSalaries.TaxableStateAllGroupMembersTotal.Amount	1.Mandatory
6.	Remuneration.WagesAndSalaries.TaxableInterstateAllGroupMembersTotal.Amount	1.Mandatory
7.	Remuneration.WagesAndSalaries.TaxableGroupStateAndInterstateTotal.Amount	1.Mandatory

Context – Designated Group Employer (DGE)		
Seq. No.	XBRL Fact	Instructions / Rules
1.	Remuneration.WagesAndSalaries.TaxableStateTotal.Amount	1. Mandatory
2.	Remuneration.WagesAndSalaries.TaxableStateAndInterstateTotal.Amount	1.Mandatory

Context – Ordinary Scheduled Member of a Scheduled Group (OSM)		
Seq. No.	XBRL Fact	Instructions / Rules
1.	Remuneration.WagesAndSalaries.TaxableStateTotal.Amount	1. Mandatory
2.	Remuneration.WagesAndSalaries.TaxableStateAndInterstateTotal.Amount	1.Mandatory

Context – Designated Group Employer of a Non Scheduled Group (DGENSEG)		
Seq. No.	XBRL Fact	Instructions / Rules
1.	Remuneration.WagesAndSalaries.OrdinaryMembersGrossTaxableAustralianWages.Amount	1.Mandatory
2.	Remuneration.WagesAndSalaries.TaxableStateAllGroupMembersTotal.Amount	1.Mandatory
3.	Remuneration.WagesAndSalaries.TaxableInterstateAllGroupMembersTotal.Amount	1.Mandatory
4.	Remuneration.WagesAndSalaries.TaxableGroupStateAndInterstateTotal.Amount	1.Mandatory

Context – Ordinary Member of a Scheduled or Non Scheduled Group (OM)		
Seq. No.	XBRL Fact	Instructions / Rules
1.	Remuneration.WagesAndSalaries.TaxableStateTotal.Amount	1. Mandatory
2.	Remuneration.WagesAndSalaries.TaxableStateAndInterstateTotal.Amount	1.Mandatory

Context – GovernmentAgency		
Seq. No.	XBRL Fact	Instructions / Rules
1.	TaxRate (Tuple: one only)	
1.1.1.	TaxRate.Type.Code	1. Mandatory
2.1.2.	TaxRate.Designation.Rate	1. Mandatory
3.2.	PayrollTax.Deduction.AnnualMaximumThreshold.Amount	1. Mandatory
4.3.	PayrollTax.YearDays.Number	1.Optional

Formatted Table

Formatted

Formatted

5.7 LODGE ANNUAL RECONCILIATION SPECIFICATIONS

Interaction Name	Lodge Annual Reconciliation
Description	The purpose of this transaction is for the business to formally lodge or re-lodge their Annual Payroll Tax Reconciliation, and optionally receive information in response to facilitate payment of the liability, or to apply for a refund
Stakeholders	Business, State Revenue Offices and Intermediaries
Pre-conditions	<ul style="list-style-type: none"> § Employer is registered for payroll tax in the State of Victoria § Employer has activated their SRO VIC customer record for SBR access via SRO VIC's portal application PTX Express § User has been authenticated via the VANguard Security Token Service (and the token is still valid). This token is valid across multiple transactions (until it expires). § Employer record details held by SRO VIC are accurate and up to date § User is authorised to lodge payroll tax on behalf of the employer, as: <ul style="list-style-type: none"> - an employee of the employer

	<ul style="list-style-type: none"> - a representative of an authorised intermediary - a representative of the Designated Group Employer, where the employer is an Ordinary Member of the group. <p>§ SRO VIC have created a blank Reconciliation (in effect the obligation) for the period and have not ceased the Reconciliation</p> <p>§ Calculate service must have been executed</p>
Post-conditions	<p>Success – The user will receive SRO VIC data to assist in preparation of their Annual Reconciliation and, if wages or tax figures were provided in the request, the payroll tax liability.</p> <p>Failure – The User will receive an Error message.</p>
Initiating party	Business
Channel	SBR
Core Service Map	Lodge

5.7.1 Lodge Annual Reconciliation Request - Message

5.7.1.1 Discoverable Taxonomy Set References

Schema	ptarvic.0001.lodge.request. 02-00.report.xsd 02.01.report.xsd
Linkbases	ptarvic.0001.lodge.request. 02-00.presLink.xml 02.01.presLink.xml
	ptarvic.0001.lodge.request. 02-00.labLinkInfoCls.xml 02.01.labLinkInfoCls.xml
	ptarvic.0001.lodge.request. 02-00.defLink.xml 02.01.defLink.xml
	ptarvic.0001.lodge.request. 02-00.refLink.xml 02.01.refLink.xml
Example Instance	N/A
Schematron	ptarvic.0001.lodge.request.02-00.sch N/A

5.7.1.2 Standard Business Document Header Content

The WIG provides the specification of the SBDH. The following table specifies the message specific data element values or any variations to the WIG.

Attribute Name	Instructions / Rules	Rule Imp	SBR Msg code
sbdm:Message.Type.Text	1. Mandatory - Value must be "ptarvic.0001.lodge.request"	1. MIG	1. SBR.GEN.GEN.4

5.7.1.3 Standard Business Document Body Content

The following describes the facts and context that must be supplied within the XBRL instance document populated into the SBDB element BusinessDocument.instance.text

The WIG provides the specification of the SBDB. The following table specifies the message specific data element values or any variations to the WIG.

Attribute Name	Rules / Values	Rule Imp	SBR Msg code
sbdm:BusinessDocument.BusinessGeneratedIdentifier.Text	1. Mandatory - Unique business-generated identifier for the lodgement request. Only a single identifier value for a given form type, reconciliation period and reporting party ABN will be accepted. Successive lodgements with duplicate values will be rejected as duplicate lodgement attempts.	1. MIG	1. VIC.SRO.GEN.1

5.7.1.3.1 Lodge Annual Reconciliation Request XBRL Context

Context Spec	Hypercube Name	Associated Segment Dimensions	Instructions / Rules	Rule Imp	SBR Msg code
ReportingParty	VICReportingParty ReportingPartyVIC	ReportPartyType, AustralianStatesTerritoriesAndOffSh oreAreas	1. There must be only one Context within the instance document. 2. The Start Date must be set to the start date relevant to the Annual Reconciliation. This date is provided in the pre-fill response. 3. The End Date must be set to the end date relevant to the Annual Reconciliation. This date is provided in the pre-fill response.	1. MIG 2. MIG 3. MIG	1. SBR.GEN.GEN.19 2. SBR.GEN.GEN.18 3. SBR.GEN.GEN.20

Context Spec	Hypercube Name	Associated Segment Dimensions	Instructions / Rules	Rule Imp	SBR Msg code
Non Group Employer (NGE)	<p>1. EmpGrpStsVICReportingParty1ReportingPartyVICNDEEDGEOMOSM</p> <p>2. EmpGrpStsVICReportingParty2ReportingPartyVICOSM (negative hypercube)</p> <p>3. EmpGrpStsVICReportingParty3ReportingPartyVICNGEDGEOSM (negative hypercube)</p> <p>4. ReportingPartyVICDGESGDGENSG</p>	ReportPartyType, AustralianStatesTerritoriesAndOffShoreAreas, EmployerGroupStatus	<p>1. There must be zero to one of this context.</p> <p>2. ABN must match the value held by SRO VIC.</p> <p>3. The Start Date must be set to the Australian start date relevant to the ABN.</p> <p>4. The End Date must be set to the Australian end date relevant to the ABN.</p> <p>5. EmployerGroupStatus must match the value held by SRO VIC.</p> <p>ABN, Start date, End date and EmployerGroupStatus were all supplied in the pre-fill response.</p>	<p>1. MIG</p> <p>2. MIG</p> <p>3. MIG</p> <p>4. MIG</p> <p>5. MIG</p>	<p>1. SBR.GEN.GEN.19</p> <p>2. VIC.SRO.PTX.36</p> <p>3. SBR.GEN.GEN.18</p> <p>4. SBR.GEN.GEN.20</p> <p>5. VIC.SRO.GEN.50</p>
Designated Group Employer (DGE)	<p>1. EmpGrpStsVICReportingParty1</p> <p>2. EmpGrpStsVICReportingParty24.ReportingPartyVICNDEEDGEOMOSM</p> <p>2. ReportingPartyVICOSM (negative hypercube)</p> <p>3. ReportingPartyVICNGEDGEOSM (negative hypercube)</p>	ReportPartyType, AustralianStatesTerritoriesAndOffShoreAreas, EmployerGroupStatus	<p>1. There must be zero to one of this context.</p> <p>2. ABN must match the value held by SRO VIC.</p> <p>3. The Start Date must be set to the Australian start date relevant to the ABN.</p> <p>4. The End Date must be set to the Australian end date relevant to the ABN.</p> <p>5. EmployerGroupStatus must match the value held by SRO VIC.</p> <p>ABN, Start date, End date and EmployerGroupStatus were all supplied in the pre-fill response.</p>	<p>1. MIG</p> <p>2. MIG</p> <p>3. MIG</p> <p>4. MIG</p> <p>5. MIG</p>	<p>1. SBR.GEN.GEN.19</p> <p>2. VIC.SRO.PTX.36</p> <p>3. SBR.GEN.GEN.18</p> <p>4. SBR.GEN.GEN.20</p> <p>5. VIC.SRO.GEN.50</p>
Designated Group Employer of a Scheduled Group (DGESG)	<p>1. DGESGDGENSGVICReportingPartyReportingPartyVICNGEDGEOSM</p> <p>2. EmpGrpStsVICReportingParty3ReportingPartyVICDGESGDGENSG</p>	ReportPartyType, AustralianStatesTerritoriesAndOffShoreAreas, EmployerGroupStatus	<p>1. There must be zero to one of this context.</p> <p>2. ABN must match the value held by SRO VIC.</p> <p>3. The Start Date must be set to the Australian start date relevant to the ABN.</p> <p>4. The End Date must be set to the Australian end date relevant to the ABN.</p> <p>5. EmployerGroupStatus must match the value held by SRO VIC.</p> <p>ABN, Start date, End date and EmployerGroupStatus were all supplied in the pre-fill response.</p>	<p>1. MIG</p> <p>2. MIG</p> <p>3. MIG</p> <p>4. MIG</p> <p>5. MIG</p>	<p>1. SBR.GEN.GEN.19</p> <p>2. VIC.SRO.PTX.36</p> <p>3. SBR.GEN.GEN.18</p> <p>4. SBR.GEN.GEN.20</p> <p>5. VIC.SRO.GEN.50</p>

Context Spec	Hypercube Name	Associated Segment Dimensions	Instructions / Rules	Rule Imp	SBR Msg code
Designated Group Employer of a Non Scheduled Group (DGENSG)	1. DGESGDGENSGVICReportingPartyReportingPartyVICNGEDGESGDGENSG 2. EmpGrpStsVICReportingParty3ReportingPartyVICDGESGDGENSG	ReportPartyType, AustralianStatesTerritoriesAndOffShoreAreas, EmployerGroupStatus	1. There must be zero to one of this context. 2. ABN must match the value held by SRO VIC. 3. The Start Date must be set to the Australian start date relevant to the ABN. 4. The End Date must be set to the Australian end date relevant to the ABN. 5. EmployerGroupStatus must match the value held by SRO VIC. ABN, Start date, End date and EmployerGroupStatus were all supplied in the pre-fill response.	1. MIG 2. MIG 3. MIG 4. MIG 5. MIG	1. SBR.GEN.GEN.19 2. VIC.SRO.PTX.36 3. SBR.GEN.GEN.18 4. SBR.GEN.GEN.20 5. VIC.SRO.GEN.50
Ordinary Scheduled Member of a Scheduled Group (OSM)	1. EmpGrpStsVICReportingParty1ReportingPartyVICNGEDGEQSM 2. ReportingPartyVICOSM (negative hypercube) 3. ReportingPartyVICNGEDGEQSM (negative hypercube)	ReportPartyType, AustralianStatesTerritoriesAndOffShoreAreas, EmployerGroupStatus	1. There must be zero to many of this context. 2. ABN must match the value held by SRO VIC. 3. The Start Date must be set to the Australian start date relevant to the ABN. 4. The End Date must be set to the Australian end date relevant to the ABN. 5. EmployerGroupStatus must match the value held by SRO VIC. ABN, Start date, End date and EmployerGroupStatus were all supplied in the pre-fill response.	1. MIG 2. MIG 3. MIG 4. MIG 5. MIG	1. SBR.GEN.GEN.19 2. VIC.SRO.PTX.36 3. SBR.GEN.GEN.18 4. SBR.GEN.GEN.20 5. VIC.SRO.GEN.50
Ordinary Member of a Scheduled or Non Scheduled Group (OM)	4. ReportingPartyVICNGEDGEQSM 2. ReportingPartyVICOSM (negative hypercube) 3. ReportingPartyVICNGEDGEQSM (negative hypercube)1 1. EmpGrpStsVICReportingParty1 2. EmpGrpStsVICReportingParty2 3. OMVICReportingParty y	ReportPartyType, AustralianStatesTerritoriesAndOffShoreAreas, EmployerGroupStatus	1. There must be zero to one of this context. 2. ABN must match the value held by SRO VIC. 3. The Start Date must be set to the Australian start date relevant to the ABN. 4. The End Date must be set to the Australian end date relevant to the ABN. 5. EmployerGroupStatus must match the value held by SRO VIC. ABN, Start date, End date and EmployerGroupStatus were all supplied in the pre-fill response.	1. MIG 2. MIG 3. MIG 4. MIG 5. MIG	1. SBR.GEN.GEN.19 2. VIC.SRO.PTX.36 3. SBR.GEN.GEN.18 4. SBR.GEN.GEN.20 5. VIC.SRO.GEN.50

Context Spec	Hypercube Name	Associated Segment Dimensions	Instructions / Rules	Rule Imp	SBR Msg code
Group Estimates (GRPEST)	DGESGDGENSGVICReportingPartyReportingPartyVICDGESGDGENSG	ReportPartyType, AustralianStatesTerritoriesAndOffShoreAreas, EmployerGroupStatus	<ol style="list-style-type: none"> There must be zero to one of this context. The ABN must match the value held by SRO VIC for the reporting party. The Start Date must be set to the start date of the financial year following the reporting party period. The End Date must be set to the end date of the financial year following the reporting party period. EmployerGroupStatus must match the value held by SRO VIC for the reporting party. <p>The reporting party's ABN and EmployerGroupStatus were supplied in the pre-fill response.</p>	<ol style="list-style-type: none"> MIG MIG MIG MIG MIG 	<ol style="list-style-type: none"> SBR.GEN.GEN.19 VIC.SRO.PTX.36 SBR.GEN.GEN.18 SBR.GEN.GEN.20 VIC.SRO.GEN.50
Reporting Party Estimates (RPEST)	1. EmpGrpStsVICReportingParty1ReportingPartyVICDGESGDGENSG	ReportPartyType, AustralianStatesTerritoriesAndOffShoreAreas, EmployerGroupStatus	<ol style="list-style-type: none"> There must be zero to one of this context. The ABN must match the value held by SRO VIC for the reporting party. The Start Date must be set to the start date of the financial year following the reporting party period. The End Date must be set to the end date of the financial year following the reporting party period. EmployerGroupStatus must match the value held by SRO VIC for the reporting party. <p>The reporting party's ABN and EmployerGroupStatus were supplied in the pre-fill response.</p>	<ol style="list-style-type: none"> MIG MIG MIG MIG MIG 	<ol style="list-style-type: none"> SBR.GEN.GEN.19 VIC.SRO.PTX.36 SBR.GEN.GEN.18 SBR.GEN.GEN.20 VIC.SRO.GEN.50
Ordinary Scheduled Member of a Scheduled Group Estimates (OSMEST)	EmpGrpStsVICReportingParty1+ReportingPartyVICNGEDGEQMSM 2-ReportingPartyVICOSM (negative hypercube) 3-ReportingPartyVICNGEDGEQMSM (negative hypercube)	ReportPartyType, AustralianStatesTerritoriesAndOffShoreAreas, EmployerGroupStatus	<ol style="list-style-type: none"> There must be zero to many of this context. The ABN must match one of the values held by SRO VIC for an OSM of this group. The Start Date must be set to the start date of the financial year following the reporting party period. The End Date must be set to the end date of the financial year following the reporting party period. EmployerGroupStatus must match the value held by SRO VIC for the OSM. <p>The OSM's ABNs and EmployerGroupStatuses were supplied in the pre-fill response.</p>	<ol style="list-style-type: none"> MIG MIG MIG MIG MIG 	<ol style="list-style-type: none"> SBR.GEN.GEN.19 VIC.SRO.PTX.36 SBR.GEN.GEN.18 SBR.GEN.GEN.20 VIC.SRO.GEN.50

Context structure within instance document:

ReportingParty.EmployerGroupStatus value	Other context to report
NGE	One RPEST
DGESG	One GRPEST One DGE

	One RPEST Zero to Many OSM Zero to Many OSMEST
DGENSG	One GRPEST One DGE One RPEST
OM	One RPEST

5.7.1.3.2 Lodge Annual Reconciliation Request Message Content Table

The following table contains the facts required in the instance document.

Context - Reporting Party				
Seq. No.	XBRL Fact	Instructions / Rules	Rule Imp.	SBR Msg Code
1.	Period.Unique.Identifier	1. Mandatory 2. As supplied by either List service.	1. MIG 2. MIG	1. VIC.SRO.GEN.2 2. VIC.SRO.PTX.28
2.	PayrollTax.Deduction.LiabilityInclusion.Indicator	1.Conditional. Mandatory for NGE, DGESG or DGENSG. 2.Conditional. Not required for OM and where PayrollTax.Deduction.LiabilityExclusion.Indicator (supplied in pre-fill response) is true.	1.MIG 2.MIG	1.VIC.SRO.PTX.31 or VIC.SRO.PTX.64 2. VIC.SRO.PTX.64
3.2.	PersonNameDetails (Tuple: one only)			
3.4.2.1.	PersonNameDetails.PersonNameType.Code	1. Mandatory 2. Use enumeration 'CNT' - Contact	1. MIG 2. MIG	1. VIC.SRO.GEN.2 2. VIC.SRO.GEN.3
3.2.2.2.	PersonNameDetails.CurrencyCode	Not required by SRO VIC	N/A	N/A
3.3.2.3.	PersonNameDetails.FamilyName.Text	1. Mandatory 2. Must not exceed the maximum length (40)	1.MIG 2.MIG	1.VIC.SRO.GEN.2 2.VIC.SRO.GEN.14
3.4.2.4.	PersonNameDetails.GivenName.Text	1.Mandatory 2. Must not exceed the maximum length (40)	1.MIG 2.MIG	1.VIC.SRO.GEN.2 2.VIC.SRO.GEN.14
3.5.2.5.	PersonNameDetails.OtherGivenName.Text	Not required by SRO VIC	N/A	N/A
4.3.	ElectronicContactTelephone (Tuple: one only)			
4.1.3.1.	ElectronicContact.Telephone.Usage.Code	1.Mandatory	1.MIG	1. VIC.SRO.GEN.2
4.2.3.2.	ElectronicContact.Telephone.ServiceLine.Code	1.Mandatory	1.MIG	1. VIC.SRO.GEN.2
4.3.3.3.	ElectronicContact.Telephone.Area.Code	1. Mandatory 2. Must not exceed the maximum length (2)	1.MIG 2.MIG	1.VIC.SRO.GEN.2 2.VIC.SRO.GEN.14

Context - Reporting Party				
Seq. No.	XBRL Fact	Instructions / Rules	Rule Imp.	SBR Msg Code
4.4.3.4.	ElectronicContact.Telephone.Minimal.Number	1.Mandatory 2. Must not exceed the maximum length (16)	1.MIG 2.MIG	1.VIC.SRO.GEN.2 2.VIC.SRO.GEN.14
4.5.4.	ElectronicContactElectronicMail (Tuple: one only)			
4.6.4.1.	ElectronicContact.ElectronicMail.Usage.Code	1.Mandatory	1.MIG	1. VIC.SRO.GEN.2
4.7.4.2.	ElectronicContact.ElectronicMail.Address.Text	1.Mandatory 2. Must not exceed the maximum length (40)	1.MIG 2.MIG	1.VIC.SRO.GEN.2 2.VIC.SRO.GEN.14
5.	PaymentReference (Tuple: zero to one)	1. Conditional. Mandatory if Payroll Tax.NetTaxPayable.Amount in Calculate response is < 0 This specifies the payment method for a customer refund	1.MIG	1. VIC.SRO.PTX.23 or VIC.SRO.PTX.56
5.1.	PaymentMechanism.CustomerReference.Number	Not required by SRO VIC		
5.2.	PaymentMechanism.PaymentMethod.Code	1.Mandatory 2.Set to 'DirectCredit' or 'Cheque'	1.MIG 2.MIG	1. VIC.SRO.PTX.23 or VIC.SRO.PTX.56 2.VIC.SRO.GEN.3
6.	DirectCredit1 (Tuple: zero to one)	1. Conditional. Mandatory if Payment Mechanism.Payment Method.Code set to 'DirectCredit'	1.MIG	1. VIC.SRO.PTX.24 or VIC.SRO.PTX.56
6.1.	PaymentMechanism.DirectCreditAccount.Identifier	Not required by SRO VIC		
6.2.	PaymentMechanism.DirectCreditName.Text	Not required by SRO VIC		
6.3.	FinancialInstitutionAccount (Tuple: zero to one)	1. Conditional. Mandatory if Payment Mechanism.Payment Method.Code set to 'DirectCredit'	1.MIG	1. VIC.SRO.PTX.24 or VIC.SRO.PTX.56
6.3.1.	FinancialInstitutionAccount.BankStateBranch.Number	1. Mandatory 2. Must not exceed the maximum length (6)	1.MIG 2.MIG	1.VIC.SRO.PTX.24 or VIC.SRO.PTX.56 2.VIC.SRO.GEN.14
6.3.2.	FinancialInstitutionAccount.FinancialInstitutionAccount.Number	1.Mandatory 2. Must not exceed the maximum length (30)	1.MIG 2.MIG	1.VIC.SRO.PTX.24 or VIC.SRO.PTX.56 2.VIC.SRO.GEN.14

Formatted

Context - Reporting Party				
Seq. No.	XBRL Fact	Instructions / Rules	Rule Imp.	SBR Msg Code
6.3.3.	FinancialInstitutionAccount.FinancialInstitutionAccountName.Text	Not required by SRO VIC		
6.3.4.	FinancialInstitutionAccount.FinancialInstitutionBranchName.Text	Not required by SRO VIC		
6.3.5.	FinancialInstitutionAccount.FinancialInstitutionName.Text	Not required by SRO VIC		
6.4.	ElectronicContactFacsimile (Tuple: zero to one)	1. Conditional. Mandatory if Payment Mechanism.Payment Method.Code set to 'DirectCredit'	1.MIG	1.VIC.SRO.PTX.24 or VIC.SRO.PTX.56
6.4.1.	ElectronicContact.Facsimile.Usage.Code	1.Mandatory Set to '02' for 'Business'	1.MIG	1. VIC.SRO.PTX.24 or VIC.SRO.PTX.56
6.4.2.	ElectronicContact.Facsimile.Area.Code	1.Mandatory 2. Must not exceed the maximum length (2)	1.MIG 2.MIG	1.VIC.SRO.PTX.24 or VIC.SRO.PTX.56 2.VIC.SRO.GEN.14
6.4.3.	ElectronicContact.Facsimile.Minimal.Number	1.Mandatory 2. Must not exceed the maximum length (16)	1.MIG 2.MIG	1.VIC.SRO.PTX.24 2.VIC.SRO.GEN.14

Context – Non Group Employer (NGE)				
Seq. No.	XBRL Fact	Instructions / Rules	Rule Imp.	SBR Msg Code
1.	Remuneration.WagesAndSalaries.Payments.Amount	1. Mandatory 2. See section 2.6.2 Format Rules, Wage Fields	1. MIG 2. See s2.6.2	1. VIC.SRO.GEN.2 2. See s2.6.2
2.	Remuneration.EmploymentAllowancesIncludingApprenticesAndTrainees.Amount	1. Mandatory 2. See section 2.6.2 Format Rules, Wage Fields	1. MIG 2. See s2.6.2	1. VIC.SRO.GEN.2 2. See s2.6.2
3.	Remuneration.CommissionsAndBonuses.Amount	1. Mandatory 2. See section 2.6.2 Format Rules, Wage Fields	1. MIG 2. See s2.6.2	1. VIC.SRO.GEN.2 2. See s2.6.2

Context – Non Group Employer (NGE)				
Seq. No.	XBRL Fact	Instructions / Rules	Rule Imp.	SBR Msg Code
4.	Remuneration.WagesAndSalaries.ContractorsAndConsultantsPayments.Amount	1. Mandatory 2. See section 2.6.2 Format Rules, Wage Fields	1. MIG 2. See s2.6.2	1. VIC.SRO.GEN.2 2. See s2.6.2
5.	Remuneration.Fees.Directors.Amount	1. Mandatory 2. See section 2.6.2 Format Rules, Wage Fields	1. MIG 2. See s2.6.2	1. VIC.SRO.GEN.2 2. See s2.6.2
6.	FringeBenefitsTax.GrossAmountMinusTaxExemptBodyEntertainment.Amount	1. Mandatory 2. See section 2.6.2 Format Rules, Wage Fields	1. MIG 2. See s2.6.2	1. VIC.SRO.GEN.2 2. See s2.6.2
7.	SuperannuationContribution.EmployerContributions.Amount	1. Mandatory 2. See section 2.6.2 Format Rules, Wage Fields 3. Warning issued if less than 9%	1. MIG 2. See s2.6.2 3. MIG	1. VIC.SRO.GEN.2 2. See s2.6.2 3. VIC.SRO.PTX.55
8.	Remuneration.EmploymentTermination.Payments.Amount	1. Mandatory 2. See section 2.6.2 Format Rules, Wage Fields	1. MIG 2. See s2.6.2	1. VIC.SRO.GEN.2 2. See s2.6.2
9.	Remuneration.EmployeeSharesAndOptions.Amount	1. Mandatory 2. See section 2.6.2 Format Rules, Wage Fields	1. MIG 2. See s2.6.2	1. VIC.SRO.GEN.2 2. See s2.6.2
10.	Remuneration.WagesAndSalaries.SharesAndOptionsOffset.Amount	1. Mandatory 2. See section 2.6.2 Format Rules, Wage Fields 3. The value cannot exceed the total of the taxable wages	1. MIG 2. See s2.6.2 3. MIG	1. VIC.SRO.GEN.2 2. See s2.6.2 3. VIC.SRO.PTX.68
11.	Remuneration.WagesAndSalaries.TaxablePayrollOther.Amount	1. Mandatory 2. See section 2.6.2 Format Rules, Wage Fields	1. MIG 2. See s2.6.2	1. VIC.SRO.GEN.2 2. See s2.6.2
12.	Remuneration.WagesAndSalaries.TaxableInterstateTotal.Amount	1. Conditional. Mandatory if employs interstate, see section 4.2.4 Employs Interstate. 2. See section 2.6.2 Format Rules, Wage Fields	1. MIG 2. See s2.6.2	1.VIC.SRO.PTX.42 or VIC.SRO.PTX.64 2. See s2.6.2
13.	PeriodDetails (Tuple: zero or one)	1. Conditional. Mandatory if the Period.End.Date where Period.Type.Code equals 'StateReconciliation' (provided in pre-fill) is 30/6 and zero entered in Estimated Gross Taxable Vic Wages, else not required.	1. MIG	1.VIC.SRO.PTX.25 or VIC.SRO.PTX.64
13.1.	Period.Type.Code	1. Mandatory 2. Set to "StateReconciliation"	1.MIG 2.MIG	1.VIC.SRO.PTX.25 or

Context – Non Group Employer (NGE)				
Seq. No.	XBRL Fact	Instructions / Rules	Rule Imp.	SBR Msg Code
				VIC.SRO.PTX.64 2. VIC.SRO.GEN.3
13.2.	Period.End.Date	1.Mandatory 2.Must match records held at SRO Victoria (i.e. must match the Period.End.Date from pre-fill response (where Period.Type.Code equals 'StateReconciliation'))	1.MIG 2.MIG	1.VIC.SRO.PTX.25 or VIC.SRO.PTX.64 2.VIC.SRO.PTX.61
14.	PeriodDetails (Tuple: zero to one)	Only supplied for Victorian interstate employers ceasing employment in Annual Reconciliation Year or Victorian-only employers commencing interstate employment in following Annual Reconciliation year		
14.1.	Period.Type.Code	1.Mandatory 2. Set to "InterstateReconciliation "	1.MIG 2.MIG	1.VIC.SRO.PTX.26 or VIC.SRO.PTX.64 2. VIC.SRO.GEN.3
14.2.	Period.Start.Date	1. Conditional. Mandatory if Vic only employer provides Estimated Interstate Wages (in RPEST context), else not required 2.Must be within the year following the Annual Reconciliation year	1.MIG 2.MIG	1.VIC.SRO.PTX.26 or VIC.SRO.PTX.64 2.VIC.SRO.PTX.62
14.3.	Period.End.Date	1. Conditional. Mandatory if the Aus Reconciliation period end date(part of context for this groupstatus type supplied in pre-fill response) is 30/6 and zero entered in Estimate Interstate Wages, else not required 2. Must be within the Victorian employment period (i.e. between Period.Start.Date and Period.End.Date from pre-fill response where Period.Type.Code equals 'StateReconciliation')Annual Reconciliation year	1.MIG 2.MIG	1.VIC.SRO.PTX.27 or VIC.SRO.PTX.64 2.VIC.SRO.PTX.63
15.	PayrollTax.TotalPaymentsMadeForAnnualPeriod.Amount	1.Mandatory 2. See section 2.6.2 Format Rules, Payment Fields	1. MIG 2. See s2.6.2	1. VIC.SRO.GEN.2 2. See s2.6.2
16.	PayrollTax.AssessedLiabilitiesPaidVariationReason.Text	1. Conditional. Mandatory if Payroll Tax.Total Payments Made For Annual Period.Amount has been changed; else Not Required 2. Must not exceed the maximum length (600)	1.MIG 2.MIG	1.VIC.SRO.PTX.44 or VIC.SRO.PTX.56 2.VIC.SRO.GEN.14
17.	StatesAndTerritoriesEmployedIn (Tuple: zero to many)	1. Conditional. Mandatory if employs interstate, see section 4.2.4 Employs Interstate.	1.MIG	1.VIC.SRO.PTX.42 or VIC.SRO.PTX.64

Context – Non Group Employer (NGE)				
Seq. No.	XBRL Fact	Instructions / Rules	Rule Imp.	SBR Msg Code
17.1.	OrganisationDetails.EmploymentStateOrTerritory.Code	1. Conditional. Mandatory if employs interstate, see section 4.2.4 Employs Interstate. 2. Valid values are: ALL or any of: NSW,QLD,NT,SA,WA,TAS, ACT	1.MIG 2.MIG	1.VIC.SRO.PTX.42 or VIC.SRO.PTX.64 2.VIC.SRO.GEN.3
18.	OrganisationDetails.HeadOfficeStateOrTerritory.Code	1. Conditional. Mandatory if employs interstate, see section 4.2.4 Employs Interstate. 2. Valid values are: one of: VIC,NSW,QLD,NT,SA,WA,TAS, ACT	1.MIG 2.MIG	1.VIC.SRO.PTX.42 or VIC.SRO.PTX.64 2.VIC.SRO.GEN.3

Context – Designated Group Employer of a Scheduled Group (DGESG)				
Seq. No.	XBRL Fact	Instructions / Rules	Rule Imp.	SBR Msg Code
1.	Remuneration.WagesAndSalaries.TotalOrdinaryMembersGrossTaxableVictorianWages.Amount	1.Mandatory 2. See section 2.6.2 Format Rules, Wage Fields	1. MIG 2. See s2.6.2	1. VIC.SRO.PTX.32 2. See s2.6.2
2.	Remuneration.WagesAndSalaries.InterstateOnlyMembersGrossTaxableInterstateWages.Amount	1. Conditional. Mandatory if group employs interstate, see section 4.2.4 Employs Interstate. 2. See section 2.6.2 Format Rules, Wage Fields	1. MIG 2. See s2.6.2	1. VIC.SRO.PTX.43 or VIC.SRO.PTX.64 2. See s2.6.2
3.	Remuneration.WagesAndSalaries.TotalOrdinaryMembersGrossTaxableInterstateWages.Amount	1. Conditional. Mandatory if group employs interstate, see section 4.2.4 Employs Interstate. 2. See section 2.6.2 Format Rules, Wage Fields	1. MIG 2. See s2.6.2	1. VIC.SRO.PTX.43 or VIC.SRO.PTX.64 2. See s2.6.2
4.	PaymentRecord.TotalPaymentsReceivedByAllOrdinaryMembers.Amount	1.Mandatory 2. See section 2.6.2 Format Rules, Payment Fields	1. MIG 2. See s2.6.2	1. VIC.SRO.PTX.32 2. See s2.6.2
5.	OrganisationDetails.HeadOfficeStateOrTerritory.Code	1. Conditional. Mandatory if any group member (Ordinary or Ordinary	1.MIG	1.

Context – Designated Group Employer of a Scheduled Group (DGESG)				
Seq. No.	XBRL Fact	Instructions / Rules	Rule Imp.	SBR Msg Code
		Scheduled or DGESG) employs interstate, see section 4.2.4 Employs Interstate 2. Valid values are: one of: VIC, NSW,QLD,NT,SA,WA,TAS, ACT	2.MIG	VIC.SRO.PTX.43 or VIC.SRO.PTX.64 2.VIC.SRO.GEN.3

Context – Designated Group Employer (DGE)				
Seq. No.	XBRL Fact	Instructions / Rules	Rule Imp.	SBR Msg Code
1.	Remuneration.WagesAndSalaries.Payments.Amount	1. Mandatory 2. See section 2.6.2 Format Rules, Wage Fields	1. MIG 2. See s2.6.2	1. VIC.SRO.GEN.2 2. See s2.6.2
2.	Remuneration.EmploymentAllowancesIncludingApprenticesAndTrainees.Amount	1. Mandatory 2. See section 2.6.2 Format Rules, Wage Fields	1. MIG 2. See s2.6.2	1. VIC.SRO.GEN.2 2. See s2.6.2
3.	Remuneration.CommissionsAndBonuses.Amount	1. Mandatory 2. See section 2.6.2 Format Rules, Wage Fields	1. MIG 2. See s2.6.2	1. VIC.SRO.GEN.2 2. See s2.6.2
4.	Remuneration.WagesAndSalaries.ContractorsAndConsultantsPayments.Amount	1. Mandatory 2. See section 2.6.2 Format Rules, Wage Fields	1. MIG 2. See s2.6.2	1. VIC.SRO.GEN.2 2. See s2.6.2
5.	Remuneration.Fees.Directors.Amount	1. Mandatory 2. See section 2.6.2 Format Rules, Wage Fields	1. MIG 2. See s2.6.2	1. VIC.SRO.GEN.2 2. See s2.6.2
6.	FringeBenefitsTax.GrossAmountMinusTaxExemptBodyEntertainment.Amount	1. Mandatory 2. See section 2.6.2 Format Rules, Wage Fields	1. MIG 2. See s2.6.2	1. VIC.SRO.GEN.2 2. See s2.6.2
7.	SuperannuationContribution.EmployerContributions.Amount	1. Mandatory 2. See section 2.6.2 Format Rules, Wage Fields 3. Warning issued if less than 9%	1. MIG 2. See s2.6.2 3. MIG	1. VIC.SRO.GEN.2 2. See s2.6.2 3. VIC.SRO.PTX.55
8.	Remuneration.EmploymentTermination.Payments.Amount	1. Mandatory 2. See section 2.6.2 Format Rules, Wage Fields	1. MIG 2. See s2.6.2	1. VIC.SRO.GEN.2 2. See s2.6.2
9.	Remuneration.EmployeeSharesAndOptions.Amount	1. Mandatory 2. See section 2.6.2 Format Rules, Wage Fields	1. MIG 2. See s2.6.2	1. VIC.SRO.GEN.2 2. See s2.6.2

Context – Designated Group Employer (DGE)				
Seq. No.	XBRL Fact	Instructions / Rules	Rule Imp.	SBR Msg Code
10.	Remuneration.WagesAndSalaries.SharesAndOptionsOffset.Amount	1.Mandatory 2. See section 2.6.2 Format Rules, Wage Fields 3. The value cannot exceed the total of the taxable wages	1. MIG 2. See s2.6.2 3. MIG	1. VIC.SRO.GEN.2 2. See s2.6.2 3. VIC.SRO.PTX.68
11.	Remuneration.WagesAndSalaries.TaxablePayrollOther.Amount	1. Mandatory 2. See section 2.6.2 Format Rules, Wage Fields	1. MIG 2. See s2.6.2	1. VIC.SRO.GEN.2 2. See s2.6.2
12.	Remuneration.WagesAndSalaries.TaxableInterstateTotal.Amount	1. Conditional. Mandatory if employs interstate, see section 4.2.4 Employs Interstate. 2. See section 2.6.2 Format Rules, Wage Fields	1. MIG 2. See s2.6.2	1.VIC.SRO.PTX.42 or VIC.SRO.PTX.64 2. See s2.6.2
13.	PeriodDetails (Tuple: zero or one)	1. Conditional. Mandatory if the Period.End.Date where Period.Type.Code equals 'StateReconciliation' (provided in pre-fill) is 30/6 and zero entered in Estimated Gross Taxable Vic Wages, else not required.	1.MIG	1.VIC.SRO.PTX.25 or VIC.SRO.PTX.64
13.1.	Period.Type.Code	1.Mandatory 2.Set to "StateReconciliation"	1.MIG 2.MIG	1.VIC.SRO.PTX.25 or VIC.SRO.PTX.64 2. VIC.SRO.GEN.3
13.2.	Period.End.Date	1.Mandatory 2.Must match records held at SRO Victoria (i.e. must match the Period.End.Date from pre-fill response (where Period.Type.Code equals 'StateReconciliation'))	1.MIG 2. MIG	1.VIC.SRO.PTX.25 or VIC.SRO.PTX.64 2.VIC.SRO.PTX.61
14.	PeriodDetails (Tuple: zero to one)	Only supplied for Victorian interstate employers ceasing employment in Annual Reconciliation Year or Victorian-only employers commencing interstate employment in following Annual Reconciliation year		
14.1.	Period.Type.Code	1.Mandatory 2.Set to "InterstateReconciliation "	1.MIG 2.MIG	1.VIC.SRO.PTX.26 or VIC.SRO.PTX.64 2. VIC.SRO.GEN.3
14.2.	Period.Start.Date	1. Conditional. Mandatory if Vic only employer provides Estimated Interstate Wages (in RPEST context), else not required 2. Must be within the year following the Annual Reconciliation year.	1.MIG 2. MIG	1.VIC.SRO.PTX.26 or VIC.SRO.PTX.64 2.VIC.SRO.PTX.62

Context – Designated Group Employer (DGE)				
Seq. No.	XBRL Fact	Instructions / Rules	Rule Imp.	SBR Msg Code
14.3.	Period.End.Date	1. Conditional. Mandatory if the Aus Reconciliation period end date (part of context for this group status type supplied in pre-fill response) is 30/6 and zero entered in Estimate Interstate Wages, else not required 2. Must be within the <u>Victorian employment period (i.e. between Period.Start.Date and Period.End.Date from pre-fill response where Period.Type.Code equals 'StateReconciliation')Annual Reconciliation year</u>	1.MIG 2. MIG	1.VIC.SRO.PTX.27 or VIC.SRO.PTX.64 2.VIC.SRO.PTX.63
15.	PayrollTax.TotalPaymentsMadeForAnnualPeriod.Amount	1. Mandatory 2. See section 2.6.2 Format Rules, Payment Fields	1. MIG 2. See s2.6.2	1. VIC.SRO.GEN.2 2. See s2.6.2
16.	PayrollTax.AssessedLiabilitiesPaidVariationReason.Text	1. Conditional. Mandatory if Payroll Tax.Total Payments Made For Annual Period.Amount t has been changed; else Not Required 2. Must not exceed the maximum length (600)	1.MIG 2.MIG	1.VIC.SRO.PTX.44 or VIC.SRO.PTX.56 2.VIC.SRO.GEN.14
17.	StatesAndTerritoriesEmployedIn (Tuple: zero to many)	1. Conditional. Mandatory if employs interstate, see section 4.2.4 Employs Interstate.	1.MIG	1. VIC.SRO.PTX.42 or VIC.SRO.PTX.64
18.	OrganisationDetails.EmploymentStateOrTerritory.Code	1. Mandatory 2. Valid values are: ALL or any of: NSW,QLD,NT,SA,WA,TAS, ACT	1.MIG 2.MIG	1.VIC.SRO.PTX.42 or VIC.SRO.PTX.64 2.VIC.SRO.GEN.3

Context – Ordinary Scheduled Member of a Scheduled Group (OSM)				
Seq. No.	XBRL Fact	Instructions / Rules	Rule Imp.	SBR Msg Code
1.	Remuneration.WagesAndSalaries.Payments.Amount	1. Mandatory 2. See section 2.6.2 Format Rules, Wage Fields	1. MIG 2. See s2.6.2	1. VIC.SRO.GEN.2 2. See s2.6.2

Context – Ordinary Scheduled Member of a Scheduled Group (OSM)				
Seq. No.	XBRL Fact	Instructions / Rules	Rule Imp.	SBR Msg Code
2.	Remuneration.EmploymentAllowancesIncludingApprenticesAndTrainees.Amount	1. Mandatory 2. See section 2.6.2 Format Rules, Wage Fields	1. MIG 2. See s2.6.2	1. VIC.SRO.GEN.2 2. See s2.6.2
3.	Remuneration.CommissionsAndBonuses.Amount	1. Mandatory 2. See section 2.6.2 Format Rules, Wage Fields	1. MIG 2. See s2.6.2	1. VIC.SRO.GEN.2 2. See s2.6.2
4.	Remuneration.WagesAndSalaries.ContractorsAndConsultantsPayments.Amount	1. Mandatory 2. See section 2.6.2 Format Rules, Wage Fields	1. MIG 2. See s2.6.2	1. VIC.SRO.GEN.2 2. See s2.6.2
5.	Remuneration.Fees.Directors.Amount	1. Mandatory 2. See section 2.6.2 Format Rules, Wage Fields	1. MIG 2. See s2.6.2	1. VIC.SRO.GEN.2 2. See s2.6.2
6.	FringeBenefitsTax.GrossAmountMinusTaxExemptBodyEntertainment.Amount	1. Mandatory 2. See section 2.6.2 Format Rules, Wage Fields	1. MIG 2. See s2.6.2	1. VIC.SRO.GEN.2 2. See s2.6.2
7.	SuperannuationContribution.EmployerContributions.Amount	1. Mandatory 2. See section 2.6.2 Format Rules, Wage Fields 3. Warning issued if less than 9%	1. MIG 2. See s2.6.2 3. MIG	1. VIC.SRO.GEN.2 2. See s2.6.2 3. VIC.SRO.PTX.55
8.	Remuneration.EmploymentTermination.Payments.Amount	1. Mandatory 2. See section 2.6.2 Format Rules, Wage Fields	1. MIG 2. See s2.6.2	1. VIC.SRO.GEN.2 2. See s2.6.2
9.	Remuneration.EmployeeSharesAndOptions.Amount	1. Mandatory 2. See section 2.6.2 Format Rules, Wage Fields	1. MIG 2. See s2.6.2	1. VIC.SRO.GEN.2 2. See s2.6.2
10.	Remuneration.WagesAndSalaries.SharesAndOptionsOffset.Amount	1. Mandatory 2. See section 2.6.2 Format Rules, Wage Fields 3. The value cannot exceed the total of the taxable wages	1. MIG 2. See s2.6.2 3. MIG	1. VIC.SRO.GEN.2 2. See s2.6.2 3. VIC.SRO.PTX.68
11.	Remuneration.WagesAndSalaries.TaxablePayrollOther.Amount	1. Mandatory 2. See section 2.6.2 Format Rules, Wage Fields	1. MIG 2. See s2.6.2	1. VIC.SRO.GEN.2 2. See s2.6.2
12.	Remuneration.WagesAndSalaries.TaxableInterstateTotal.Amount	1. Conditional. Mandatory if employs interstate, see section 4.2.4 Employs Interstate. 2. See section 2.6.2 Format Rules, Wage Fields	1. MIG 2. See s2.6.2	1. VIC.SRO.PTX.42 or VIC.SRO.PTX.64 2. See s2.6.2
13.	PeriodDetails (Tuple: zero or one)	1. Conditional. Mandatory if the Period.End.Date where Period.Type.Code equals 'StateReconciliation' (provided in pre-fill) is 30/6 and zero entered in Remuneration.WagesAndSalaries.TaxableStateTotal.Amount Estimated Gross Taxable Vic wages,	1. MIG	1. VIC.SRO.PTX.25 or VIC.SRO.PTX.64

Context – Ordinary Scheduled Member of a Scheduled Group (OSM)				
Seq. No.	XBRL Fact	Instructions / Rules	Rule Imp.	SBR Msg Code
		else not required.		
13.1.	Period.Type.Code	1.Mandatory 2.Set to "StateReconciliation"	1.MIG 2.MIG	1.VIC.SRO.PTX.25 or VIC.SRO.PTX.64 2.VIC.SRO.GEN.3
13.2.	Period.End.Date	1.Mandatory 2.Must match records held at SRO Victoria (i.e. <u>must match the Period.End.Date from pre-fill response (where Period.Type.Code equals 'StateReconciliation')</u>)	1.MIG <u>2. MIG</u>	1.VIC.SRO.PTX.25 or VIC.SRO.PTX.64 2.VIC.SRO.PTX.61
14.	PeriodDetails (Tuple: zero to one)	Only supplied for Victorian interstate employers, see section 4.2.4 Employs Interstate, ceasing employment in Annual Reconciliation Year or Victorian-only employers commencing interstate employment in following Annual Reconciliation year		
14.1.	Period.Type.Code	1.Mandatory 2.Set to "InterstateReconciliation "	1.MIG 2.MIG	1.VIC.SRO.PTX.26 or VIC.SRO.PTX.64 2.VIC.SRO.GEN.3
14.2.	Period.Start.Date	1. Conditional. Mandatory if Vic only employer provides Estimated Interstate Wages (in RPEST context), else not required 2. Must be within the year following the Annual Reconciliation year	1.MIG <u>2. MIG</u>	1.VIC.SRO.PTX.26 or VIC.SRO.PTX.64 2.VIC.SRO.PTX.62
14.3.	Period.End.Date	1. Conditional. Mandatory if <u>the Aus Reconciliation period end date (part of context for this group status type supplied in pre-fill response) is 30/6 and</u> zero entered in Estimate Interstate Wages, else not required 2. Must be within the <u>Victorian employment period (i.e. between Period.Start.Date and Period.End.Date from pre-fill response where Period.Type.Code equals 'StateReconciliation')</u> Annual Reconciliation year	1.MIG <u>2. MIG</u>	1.VIC.SRO.PTX.27 or VIC.SRO.PTX.64 2.VIC.SRO.PTX.63
15.	StatesAndTerritoriesEmployedIn (Tuple: zero to many)	1. Conditional. Mandatory if employs interstate, see section 4.2.4 Employs Interstate	1.MIG	1. VIC.SRO.PTX.42 or VIC.SRO.PTX.64
15.1.	OrganisationDetails.EmploymentStateOrTerritory.Code	1. Mandatory 2. Valid values are: <u>ALL</u> or any of: NSW,QLD,NT,SA,WA,TAS, ACT	1.MIG 2.MIG	1. VIC.SRO.PTX.42 or VIC.SRO.PTX.64 2.VIC.SRO.GEN.3

Context – Designated Group Employer of a Non Scheduled Group (DGENSG)				
Seq. No.	XBRL Fact	Instructions / Rules	Rule Imp.	SBR Msg Code
1.	Remuneration.WagesAndSalaries.TotalOrdinaryMembersGrossTaxableVictorianWages.Amount	1.Mandatory 2. See section 2.6.2 Format Rules, Wage Fields	1. MIG 2. See s2.6.2	1. VIC.SRO.PTX.32 2. See s2.6.2
2.	Remuneration.WagesAndSalaries.InterstateOnlyMembersGrossTaxableInterstateWages.Amount	1. Conditional. Mandatory if group employs interstate. 2. See section 2.6.2 Format Rules, Wage Fields	1. MIG 2. See s2.6.2	1. VIC.SRO.PTX.43 or VIC.SRO.PTX.64 2. See s2.6.2
3.	Remuneration.WagesAndSalaries.TotalOrdinaryMembersGrossTaxableInterstateWages.Amount	1. Conditional. Mandatory if group employs interstate, see section 4.2.4 Employs Interstate 2. See section 2.6.2 Format Rules, Wage Fields	1. MIG 2. See s2.6.2	1. VIC.SRO.PTX.43 or VIC.SRO.PTX.64 2. See s2.6.2
4.	PaymentRecord.TotalPaymentsReceivedByAllOrdinaryMembers.Amount	1.Mandatory 2. See section 2.6.2 Format Rules, Payment Fields	1. MIG 2. See s2.6.2	1. VIC.SRO.PTX.32 2. See s2.6.2
5.	OrganisationDetails.HeadOfficeStateOrTerritory.Code	1. Conditional. Mandatory if any group member (Ordinary or Ordinary Scheduled or DGENSG) employs interstate, see section 4.2.4 Employs Interstate 2. Valid values are: one of: VIC,NSW,QLD,NT,SA,WA,TAS,ACT	1.MIG 2.MIG	1. VIC.SRO.PTX.43 or VIC.SRO.PTX.64 2.VIC.SRO.GEN.3

Context – Ordinary Member of a Scheduled or Non Scheduled Group (OM)				
Seq. No.	XBRL Fact	Instructions / Rules	Rule Imp.	SBR Msg Code
1.	Remuneration.WagesAndSalaries.Payments.Amount	1. Mandatory 2. See section 2.6.2 Format Rules, Wage Fields	1. MIG 2. See s2.6.2	1. VIC.SRO.GEN.2 2. See s2.6.2
2.	Remuneration.EmploymentAllowancesIncludingApprenticesAndTrainees.Amount	1. Mandatory 2. See section 2.6.2 Format Rules, Wage Fields	1. MIG 2. See s2.6.2	1. VIC.SRO.GEN.2 2. See s2.6.2
3.	Remuneration.CommissionsAndBonuses.Amount	1. Mandatory 2. See section 2.6.2 Format Rules, Wage Fields	1. MIG 2. See s2.6.2	1. VIC.SRO.GEN.2 2. See s2.6.2
4.	Remuneration.WagesAndSalaries.ContractorsAndConsultantsPayments.Amount	1. Mandatory 2. See section 2.6.2 Format Rules, Wage Fields	1. MIG 2. See s2.6.2	1. VIC.SRO.GEN.2 2. See s2.6.2

Context – Ordinary Member of a Scheduled or Non Scheduled Group (OM)				
Seq. No.	XBRL Fact	Instructions / Rules	Rule Imp.	SBR Msg Code
5.	Remuneration.Fees.Directors.Amount	1. Mandatory 2. See section 2.6.2 Format Rules, Wage Fields	1. MIG 2. See s2.6.2	1. VIC.SRO.GEN.2 2. See s2.6.2
6.	FringeBenefitsTax.GrossAmountMinusTaxExemptBodyEntertainment.Amount	1. Mandatory 2. See section 2.6.2 Format Rules, Wage Fields	1. MIG 2. See s2.6.2	1. VIC.SRO.GEN.2 2. See s2.6.2
7.	SuperannuationContribution.EmployerContributions.Amount	1. Mandatory 2. See section 2.6.2 Format Rules, Wage Fields 3. Warning issued if less than 9%	1. MIG 2. See s2.6.2 3. MIG	1. VIC.SRO.GEN.2 2. See s2.6.2 3. VIC.SRO.PTX.55
8.	Remuneration.EmploymentTermination.Payments.Amount	1. Mandatory 2. See section 2.6.2 Format Rules, Wage Fields	1. MIG 2. See s2.6.2	1. VIC.SRO.GEN.2 2. See s2.6.2
9.	Remuneration.EmployeeSharesAndOptions.Amount	1. Mandatory 2. See section 2.6.2 Format Rules, Wage Fields	1. MIG 2. See s2.6.2	1. VIC.SRO.GEN.2 2. See s2.6.2
10.	Remuneration.WagesAndSalaries.SharesAndOptionsOffset.Amount	1.Mandatory 2. See section 2.6.2 Format Rules, Wage Fields 3. The value cannot exceed the total of the taxable wages	1. MIG 2. See s2.6.2 3. MIG	1. VIC.SRO.GEN.2 2. See s2.6.2 3. VIC.SRO.PTX.68
11.	Remuneration.WagesAndSalaries.TaxablePayrollOther.Amount	1. Mandatory 2. See section 2.6.2 Format Rules, Wage Fields	1. MIG 2. See s2.6.2	1. VIC.SRO.GEN.2 2. See s2.6.2
12.	Remuneration.WagesAndSalaries.TaxableInterstateTotal.Amount	1. Conditional. Mandatory if employs interstate, see section 4.2.4 Employs Interstate 2. See section 2.6.2 Format Rules, Wage Fields	1. MIG 2. See s2.6.2	1. VIC.SRO.PTX.42 or VIC.SRO.PTX.64 2. See s2.6.2
13.	PeriodDetails (Tuple: zero or one)	1. Conditional. Mandatory if the Period.End.Date where Period.Type.Code equals 'StateReconciliation' (provided in pre-fill) is 30/6 and zero entered in Estimated Gross Taxable Vic Wages, else not required.	1. MIG	1. VIC.SRO.PTX.25 or VIC.SRO.PTX.64
13.1.	Period.Type.Code	1.Mandatory 2.Set to "StateReconciliation"	1.MIG 2.MIG	1.VIC.SRO.PTX.25 or VIC.SRO.PTX.64 2.VIC.SRO.GEN.3
13.2.	Period.End.Date	1.Mandatory 2.Must match records held at SRO Victoria (i.e. must match the Period.End.Date from pre-fill response (where Period.Type.Code equals 'StateReconciliation'))	1.MIG 2. MIG	1.VIC.SRO.PTX.25 or VIC.SRO.PTX.64 2.VIC.SRO.PTX.61
14.	PeriodDetails (Tuple: zero to one)	Only supplied for Victorian interstate employers, see section 4.2.4 Employs Interstate, ceasing employment in Annual Reconciliation Year or		

Context – Ordinary Member of a Scheduled or Non Scheduled Group (OM)				
Seq. No.	XBRL Fact	Instructions / Rules	Rule Imp.	SBR Msg Code
		Victorian-only employers commencing interstate employment in following Annual Reconciliation year		
14.1.	Period.Type.Code	1.Mandatory 2.Set to "InterstateReconciliation "	1.MIG 2.MIG	1.VIC.SRO.PTX.26 or VIC.SRO.PTX.64 2. VIC.SRO.GEN.3
14.2.	Period.Start.Date	1. Conditional. Mandatory if Vic only employer provides Estimated Interstate Wages (see in RPEST context), else not required 2. Must be within the year following the Annual Reconciliation year	1.MIG 2. MIG	1.VIC.SRO.PTX.26 or VIC.SRO.PTX.64 2.VIC.SRO.PTX.62
14.3.	Period.End.Date	1. Conditional. Mandatory if the Aus Reconciliation period end date (part of context for this group status type supplied in pre-fill response) is 30/6 and zero entered in Estimate Interstate Wages, else not required 2. Must be within the Victorian employment period (i.e. between Period.Start.Date and Period.End.Date from pre-fill response where Period.Type.Code equals 'StateReconciliation')Annual Reconciliation year	1.MIG 2. MIG	1.VIC.SRO.PTX.27 or VIC.SRO.PTX.64 2.VIC.SRO.PTX.63
15.	PayrollTax.TotalPaymentsMadeForAnnualPeriod.Amount	1.Mandatory 2. See section 2.6.2 Format Rules, Payment Fields	1. MIG 2. See s2.6.2	1. VIC.SRO.GEN.2 2. See s2.6.2
16.	PayrollTax.AssessedLiabilitiesPaidVariationReason.Text	1. Conditional. Mandatory if Payroll Tax.Total Payments Made For Annual Period.Amount has been changed; else Not Required 2. Must not exceed the maximum length (600)	1.MIG 2.MIG	1.VIC.SRO.PTX.44 or VIC.SRO.PTX.56 2.VIC.SRO.GEN.14
17.	EmployerConditions.GroupMember.InformationDisclosureAuthorisation.Indicator	1.Mandatory	1.MIG	1.VIC.SRO.PTX.34
18.	Preferences.PartyResponsibleForPayment.Indicator	1.Mandatory	1.MIG	1.VIC.SRO.PTX.34
19.	StatesAndTerritoriesEmployedIn (Tuple: zero to many)	1. Conditional. Mandatory if employs interstate, see section 4.2.4 Employs Interstate.	1.MIG	1. VIC.SRO.PTX.42 or VIC.SRO.PTX.64
19.1.	OrganisationDetails.EmploymentStateOrTerritory.Code	1. Mandatory 2. Valid values are: ALL or any of: NSW,QLD,NT,SA,WA,TAS, ACT	1.MIG 2.MIG	1. VIC.SRO.PTX.42 or VIC.SRO.PTX.64 2.VIC.SRO.GEN.3

Context – Group Estimates (GRPEST)				
Seq. No.	XBRL Fact	Instructions / Rules	Rule Imp.	SBR Msg Code
1.	Remuneration.WagesAndSalaries.TaxableStateAllGroupMembersTotal.Amount	1.Mandatory 2. See section 2.6.2 Format Rules, Wage Fields 3. Group Victorian Estimates must be greater than or equal to Reporting Party Victorian Estimates	1. MIG 2. See s2.6.2 3. MIG	1. VIC.SRO.PTX.32 2. See s2.6.2 3. VIC.SRO.PTX.69
2.	Remuneration.WagesAndSalaries.TaxableInterstateAllGroupMembersTotal.Amount	1. Conditional. Mandatory if employs interstate , see section 4.2.4 Employs Interstate. 2. See section 2.6.2 Format Rules, Wage Fields 3. Group Interstate Estimates must be greater than or equal to Reporting Party Interstate estimates	1. MIG 2. See s2.6.2 3. MIG	1. VIC.SRO.PTX.43 or VIC.SRO.PTX.64 See s2.6.2 3. VIC.SRO.PTX.70

Context – Reporting Party Estimates (RPEST)				
Seq. No.	XBRL Fact	Instructions / Rules	Rule Imp.	SBR Msg Code
1.	Remuneration.WagesAndSalaries.TaxableStateTotal.Amount	1.Mandatory 2. See section 2.6.2 Format Rules, Wage Fields	1. MIG 2. See s2.6.2	1. VIC.SRO.GEN.2 2. See s2.6.2
2.	Remuneration.WagesAndSalaries.TaxableInterstateTotal.Amount	1. Conditional. Mandatory if employs interstate , see section 4.2.4 Employs Interstate . 2. See section 2.6.2 Format Rules, Wage Fields	1. MIG 2. See s2.6.2	1. VIC.SRO.PTX.42 or VIC.SRO.PTX.64 2. See s2.6.2

Context – Ordinary Scheduled Member of a Scheduled Group Estimates (OSMEST)				
Seq. No.	XBRL Fact	Instructions / Rules	Rule Imp.	SBR Msg Code

Context – Ordinary Scheduled Member of a Scheduled Group Estimates (OSMEST)				
Seq. No.	XBRL Fact	Instructions / Rules	Rule Imp.	SBR Msg Code
1.	Remuneration.WagesAndSalaries.TaxableStateTotal.Amount	1.Mandatory 2. See section 2.6.2 Format Rules, Wage Fields	1. MIG 2. See s2.6.2	1. VIC.SRO.GEN.2 2. See s2.6.2
2.	Remuneration.WagesAndSalaries.TaxableInterstateTotal.Amount	1. Conditional. Mandatory if employs interstate , see section 4.2.4 Employs Interstate . 2. See section 2.6.2 Format Rules, Wage Fields	1. MIG 2. See s2.6.2	1. VIC.SRO.PTX.42 or VIC.SRO.PTX.64 2. See s2.6.2

5.7.2 Lodge Annual Reconciliation Response - Message

5.7.2.1 Discoverable Taxonomy Set References

Schema	ptarvic.0001.lodge.response. 02.00.report.xsd 02.01.report.xsd
Linkbases	ptarvic.0001.lodge.response. 02.00.presLink.xml 02.01.presLink.xml
	ptarvic.0001.lodge.response. 02.00.labLinkInfoCls.xml 02.01.labLinkInfoCls.xml
	ptarvic.0001.lodge.response. 02.00.defLink.xml 02.01.defLink.xml
	ptarvic.0001.lodge.response. 02.00.refLink.xml 02.01.refLink.xml
Example Instance	N/A

5.7.2.2 Standard Business Document Header Content

The WIG provides the specification of the SBDH. The following table specifies the message specific data element values or any variations to the WIG.

Attribute Name	Instructions / Rules
sbdm:Message.Type.Text	1. Mandatory - Value must be "ptarvic.0001.lodge.response"
sbdm:Lodgement.Receipt.Identifier	1. Optional. A unique agency identifier for the Lodgement. Populated for successful lodgements only.
sbdm:Lodgement.Receipt.Datetime	1. Optional. The date and time at which the agency accepted the lodgement request. Populated for successful lodgements only.
sbdm:Message.Event.Item.Error.Code	<p>1. Mandatory – if successful, will be one of the following:</p> <ul style="list-style-type: none"> • VIC.SRO.PTX.37 • VIC.SRO.PTX.54 • VIC.SRO.PTX.60 • VIC.SRO.PTX.67 <p>If duplicate lodgement, will be:</p> <ul style="list-style-type: none"> • VIC.SRO.GEN.1 <p>and one of the following</p> <ul style="list-style-type: none"> • VIC.SRO.PTX.37 • VIC.SRO.PTX.54 • VIC.SRO.PTX.60 • VIC.SRO.PTX.67 <p>Error code for failed lodgements will be as documented in this document and the SRO VIC response messages repository.</p>

5.7.2.3 Standard Business Document Body Content

The following describes the facts and context that must be supplied within the XBRL instance document populated into the SBDB element BusinessDocument.instance.text

5.7.2.3.1 Lodge Annual Reconciliation Response XBRL Context

Context Spec	Hypercube Name	Associated Segment Dimensions	Instructions / Rules
ReportingParty	VICReportingPartyRe portingPartyVIC	ReportPartyType, AustralianStatesTerritoriesAndOffSh oreAreas	1. There must be only one Context within the instance document. 2. The Start Date will be set to the start date relevant to the Annual Reconciliation. 3. The End Date will be set to the end date relevant to the Annual Reconciliation.
GovernmentAgency	GovernmentAgencyG overnmentAgency	ReportPartyType	1. There must be only one Context within the instance document. 2. The Start Date will be set to the start date relevant to the Annual Reconciliation. 3. The End Date will be set to the end date relevant to the Annual Reconciliation.

5.7.2.3.2 Lodge Annual Reconciliation Response Message Content Table

The following table contains the facts that may be returned within the instance document. Elements that form part of common tuples but are not used by SRO VIC are indicated by "Not required by SRO VIC" in the 'Instructions Rules' column. To ensure that the following table is interpreted correctly please Refer to Appendix A for a detailed description of each column.

Context - Reporting Party		
Seq. No.	XBRL Fact	Instructions / Rules
1.	Lodgment.Received.Date	1. Mandatory
2.	Lodgment.Received.Time	1. Mandatory
3.	ObligationDetail (Tuple: zero to one)	
3.1.	PaymentReference (Tuple: zero to many)	
3.1.1.	PaymentMechanism.CustomerReference.Number	1. Conditional. Mandatory if PaymentMethod.Code equals 'DirectCredit' or 'BPay'.
3.1.2.	PaymentMechanism.PaymentMethod.Code	1. Mandatory

Context – GovernmentAgency		
----------------------------	--	--

Seq. No.	XBRL Fact	Instructions / Rules
1.	PaymentMechanism (Tuple: zero to many)	
1.1.	PaymentMechanism.PaymentMethod.Code	1. Mandatory
1.2.	PaymentMechanism.Instruction.Text	1. Conditional. Mandatory if PaymentMethod.Code equals 'DirectDebit' or 'Cheque' or 'InPerson'.
1.3.	DirectCredit ⁴ (Tuple: zero to one)	
1.3.1.	PaymentMechanism.DirectCreditAccount.Identifier	1. Not required by SRO VIC
1.3.2.	PaymentMechanism.DirectCreditName.Text	1. Not required by SRO VIC
1.3.3.	FinancialInstitutionAccount (Tuple: one only)	
1.3.3.1.	FinancialInstitutionAccount.BankStateBranch.Number	1. Mandatory
1.3.3.2.	FinancialInstitutionAccount.FinancialInstitutionAccount.Number	1. Mandatory
1.3.3.3.	FinancialInstitutionAccount.FinancialInstitutionAccountName.Text	1. Not required by SRO VIC
1.3.3.4.	FinancialInstitutionAccount.FinancialInstitutionBranchName.Text	1. Not required by SRO VIC
1.3.3.5.	FinancialInstitutionAccount.FinancialInstitutionName.Text	1. Not required by SRO VIC
1.4.	Bpay ⁴ (Tuple: zero to one)	
1.4.1.	PaymentMechanism.BpayBiller.Code	1. Mandatory
1.5.	PaymentInPerson (Tuple: zero to one)	
1.5.1.	AddressDetails (Tuple: one only)	
1.5.2.	AddressDetails.OverseasAddress.Indicator	1. Not required by SRO VIC

Context – GovernmentAgency		
Seq. No.	XBRL Fact	Instructions / Rules
1.5.3.	AddressDetails.Usage.Code	1. Mandatory
1.5.4.	AddressDetails.AttentionTo.Text	1. Not required by SRO VIC
1.5.5.	AddressDetails.Line1.Text	1. Mandatory
1.5.6.	AddressDetails.Line2.Text	1. Optional
1.5.7.	AddressDetails.Line3.Text	1. Not required by SRO VIC
1.5.8.	AddressDetails.Line4.Text	1. Not required by SRO VIC
1.5.9.	AddressDetails.LocalityName.Text	1. Mandatory
1.5.10.	AddressDetails.Postcode.Text	1. Optional
1.5.11.	AddressDetails.StateOrTerritory.Code	1. Optional
1.5.12.	AddressDetails.CountryName.Text	1. Not required by SRO VIC
1.5.13.	AddressDetails.Country.Code	1. Not required by SRO VIC

APPENDIX A – THE MESSAGE CONTENT TABLE EXPLAINED

This section defines the table structure that **must** be used to define the context, structure, and rules of the data elements contained within the XBRL instance document – referred to as the message content table.

There will be a message content table for each context within the message. The grouping of the data elements in accordance to the context aligns to how the data elements are built into the XBRL taxonomy and this consistent presentation will assist Software Developers.

The message content table uses the following rows and columns:

Context Type (row at top of table): This is the name of the XBRL Context Specification or Context Instance which has been defined early in the MIG document.

Sequence Number: This is a sequential number used to indicate the expected order of the data elements within the instance document and to describe the structure of tuples. Data elements within a tuple are allocated a multilevel number to indicate the expected structure and order of the data elements contained within the tuple. If there are nested tuples then the sequence number goes to next numbering level. The following is an extract from a message content table which illustrates the sequence numbering and multi-levelling required to cater for tuples and nested tuples.

Seq No.	XBRL Fact
1.	PaymentMechanism (Tuple: zero to many)
1.1.	PaymentMechanism.PaymentMethod.Code
1.2.	PaymentMechanism.Instruction.Text
1.3.	DirectDebit (Tuple zero to one)
1.3.1.	Payment Mechanism.Direct DebitAccount.Identifier
1.3.2.	Payment Mechanism.Direct Debit Name.Text
1.4.	DirectCredit (Tuple zero to one)
1.4.1.	Payment Mechanism.Direct CreditAccount.Identifier
1.4.2.	Payment Mechanism.Direct CreditName.Text
1.4.3.	FinancialInstitutionAccount (Tuple One Only)
1.4.3.1.	FinancialInstitutionAccount.BankStateBranch.Number
1.4.3.2.	FinancialInstitutionAccount.FinancialInstitutionAccount.Number
1.4.3.3.	FinancialInstitutionAccount.FinancialInstitutionAccountName.Text
1.4.3.4.	FinancialInstitutionAccount.FinancialInstitutionBranchName.Text
1.4.3.5.	FinancialInstitutionAccount.FinancialInstitutionName.Text

XBRL Fact: This is the name of the data element to be reported. For example:

Identifiers.AustralianBusinessNumber.Identifier

Instructions / Rules: This column describes all the instructions / rules applicable to the data element. Each rule needs to be given a sequential number which links the rule to its implementation and message code. Rules would include information such as optionality, presentation criteria and the use of XML attributes such as IsVisible.

Rule Implementation: This column informs Software Developers how the rules specified in the Rules column will be provided.

NOTE: This column is only applicable for request messages and the column will not be present in the table for Response Messages.

There can only be the following options:

- XBRL – validation provided via the XBRL schemas and linkbases. Typically rules implemented via XBRL do not need to be specified within the MIG. Only those rules that are considered to provide necessary information to software developers should be defined within the MIG. An example of this is the rules associated with the domain values of a dimension within a context specification.
- ~~Schematron ID – for rules that cannot be implemented using XBRL some agencies will provide a Schematron implementation of the rule. When Schematron is provided then the unique ID used to identify the rule within the Schematron file must be provided within the MIG. The following is an example of how this should appear in the column ::Schematron ID = VICMIG004~~
- MIG - There will be situations where rules will not be provided to Software Developers in a machine readable format and the description of the rule in the MIG is all that will be provided. In this situation the Software Developer has the choice of either implementing the rule as specified within the MIG or they to rely on the agency to validate the data element (the expectation is that the Agency will always test for this rule)
- Agency – This rule cannot be implemented by the Software Developer and can only be executed by the agency.

SBR Message Code: All messages returned via the SBR channel will contain a code to uniquely identify the condition that has occurred.

NOTE: This column is only applicable for request messages and the column will not be present in the table for Response Messages.

In order to allow codes to be managed in a distributed fashion, codes will take the following format:

{Jurisdiction}.{Agency}.{Function}.{Id}

represented by the regular expression

([A-Z0-9])+.([A-Z0-9])+.([A-Z0-9])+.([A-Z0-9])+

Initially

Jurisdiction = SBR | CMN | QLD | NSW | ACT | VIC | SA | WA | NT | TAS

Agency = Jurisdiction specific agency code

For CMN (Commonwealth), = ATO, ASIC, APRA, ABS

For SBR = GEN (i.e. SBR wide codes)

For States = OSR of Offices of State Revenue

Function = Agency specific functional area or GEN for agency wide codes

For SBR = GEN or FAULT

Id = function specific identifier (format may vary across agencies).

Examples are shown below;

SBR.GEN.FAULT.TOOMANYINSTANCES

CMN.ATO.TFN.OK

QLD.OSR.PRL.000001

The above structure recognises and caters for the current situation where agency errors are unharmonised, and will need to be passed through to client software.

The expectation is that for each rule identified within the message content table ~~to will~~ have a corresponding message code however depending on the rule implementation a message code may not be relevant in which case Not Applicable (N/A) should be inserted into the rule's corresponding message code to make this clear to Software Developers. The follow table summaries what must be provided in the message code column in relation to the rules implementation choice.

Rule Implementation	Message Code
Schematron	Message Code needs to be provided against corresponding rule.
XBRL	Message Code not relevant – place N/A against corresponding rule.
MIG	Message Code needs to be provided against corresponding rule. The only exception is if the rule is associated to with a rendering instruction to the software developer.
Agency	Message Code needs to be provided against corresponding rule.

The expectation is that each agency will populate a message repository with all error, warning and information messages that could be returned via the SBR channel. These messages will be allocated an SBR message code using the above mentioned code format. The Software Developer would then use the SBR message code provided via the MIG and the message repository to obtain the full details associated with the message.